

# MASTERTRACE

# MS-2102

---

HEAT TRACING CONTROL

## OPERATOR'S MANUAL

---

<b>1 Product Overview .....</b>	<b>1.1</b>
Introduction .....	1.1
Specifications .....	1.2
Summary of Features .....	1.3
Use of this Manual .....	1.3
Conventions .....	1.3
Shipping Content .....	1.3
Theory of Operation .....	1.4
<b>2 Installation .....</b>	<b>2.1</b>
Unpacking the Controller .....	2.1
Control Module .....	2.1
Mounting the Controller .....	2.3
Wire Sizing .....	2.3
Conduit and Cabling .....	2.3
Power Wiring .....	2.3
Heater Wiring .....	2.3
Ground Connection .....	2.3
RTD Sensor Wiring .....	2.3
Communication Wiring .....	2.4
Alarm Wiring .....	2.4
<b>3 Getting Started .....</b>	<b>3.1</b>
Introduction .....	3.1
Selecting the Heater .....	3.1
Enabling the Heater .....	3.1
Entering Setpoints .....	3.1
Testing Heater & Alarms .....	3.3
Monitoring System Status .....	3.4
<b>4 Front Panel Operation .....</b>	<b>4.1</b>
Overview .....	4.1
Operating the Keypad .....	4.1
Status Lights .....	4.1
Alphanumeric Display .....	4.1
Keypad .....	4.1
Display Contrast .....	4.1
Heater Numbering .....	4.1
Startup Messages .....	4.3
Status Messages .....	4.3
Flash Messages .....	4.4
<b>5 Measured Values .....</b>	<b>5.1</b>
Overview .....	5.1
Operating .....	5.2
Statistics .....	5.4
<b>6 Setpoint Values .....</b>	<b>6.1</b>
Overview .....	6.1
Setpoints Entering .....	6.2
Setpoint Access Security .....	6.2
Operating .....	6.2
Heater Setup .....	6.7
System Setup .....	6.9
Setpoint Tests .....	6.11

---

<b>7 Alarms .....</b>	<b>7.1</b>
Overview .....	7.1
Trip or Failure Alarms .....	7.1
Process Alarms .....	7.2
Warning Alarms .....	7.2
Reset Alarms .....	7.3
<b>8 Communications .....</b>	<b>8.1</b>
Overview .....	8.1
Physical Layer .....	8.1
Modbus Protocol .....	8.1
Modbus Memory Map .....	8.4
<b>9 Commissioning .....</b>	<b>9.1</b>
Overview .....	9.1
Requirements .....	9.1
RTD Input Test .....	9.1
Heater Voltage and Current Test (MS2102 controller only) .....	9.2
Ground Fault Current Test .....	9.3
Alarm Output Test .....	9.3
Override Input Test .....	9.3
Placing the Controller in Service .....	9.4
Completing the Installation .....	9.5
<b>10 Ethernet Communications .....</b>	<b>10.1</b>
Ethernet Communication in BACnet/IP and MS-2102 Model Option "BAC/BAC1" .....	10.1
Serial Communication in BACnet MS/TP network .....	10.2
Ethernet Communication in Modbus TCP and MS-2102 Model Option "ETH/ETH1" .....	10.3
An Important Note on Ethernet Gateways .....	10.4
<b>Warranty .....</b>	<b>Back Cover</b>

## Introduction

The MS-2102 two-point heat tracing controller uses a microprocessor and is intended for stand-alone heat trace applications. It can be for use with mineral-insulated, self-regulating or constant-wattage cable for freeze protection, process control and instrument tracing. The MS-2102 is intended for indoor or outdoor installations in ordinary or hazardous locations.

MS-2102 offers many advantages over other heat tracing control schemes, which generally use some combination of mechanical thermostats, custom-built panels or programmable controls to provide control, monitoring and alarm functions. Budgetary constraints usually limit the degree of system fault monitoring to less than optimal levels. This results in periodic costly process shutdowns due to process or hardware malfunctions. Equipment reliability concerns often force plant procedures to include annual thermostat performance checks to ensure that the device is still operating as intended. This can be a tedious, labour intensive job.

A MS2102 Control Module is mounted near the pipes being traced to monitor the heater points. This Control Module can communicate with a single master unit to give complete system monitoring and control from a convenient location. Up to 32 Control Modules can be monitored on a RS485 data highway to a centrally located master. By connecting Control Modules to a data highway, the MS-2102 can immediately flag alarms caused by heat tracing malfunctions, altered setpoints and monitor actual values from a central location. Each local Control Module is completely independent and will continue to function if the master fails or if the communication link fails. This ensures maximum reliability and minimizes vulnerability in the event of a hardware failure. Additional points can easily be added at any time as easily as a mechanical thermostat can be installed. Unlike control schemes using programmable controllers, no software development is required. The complete system is operational as soon as it is installed.

Figure 1.1 Typical MS-2102 Installation

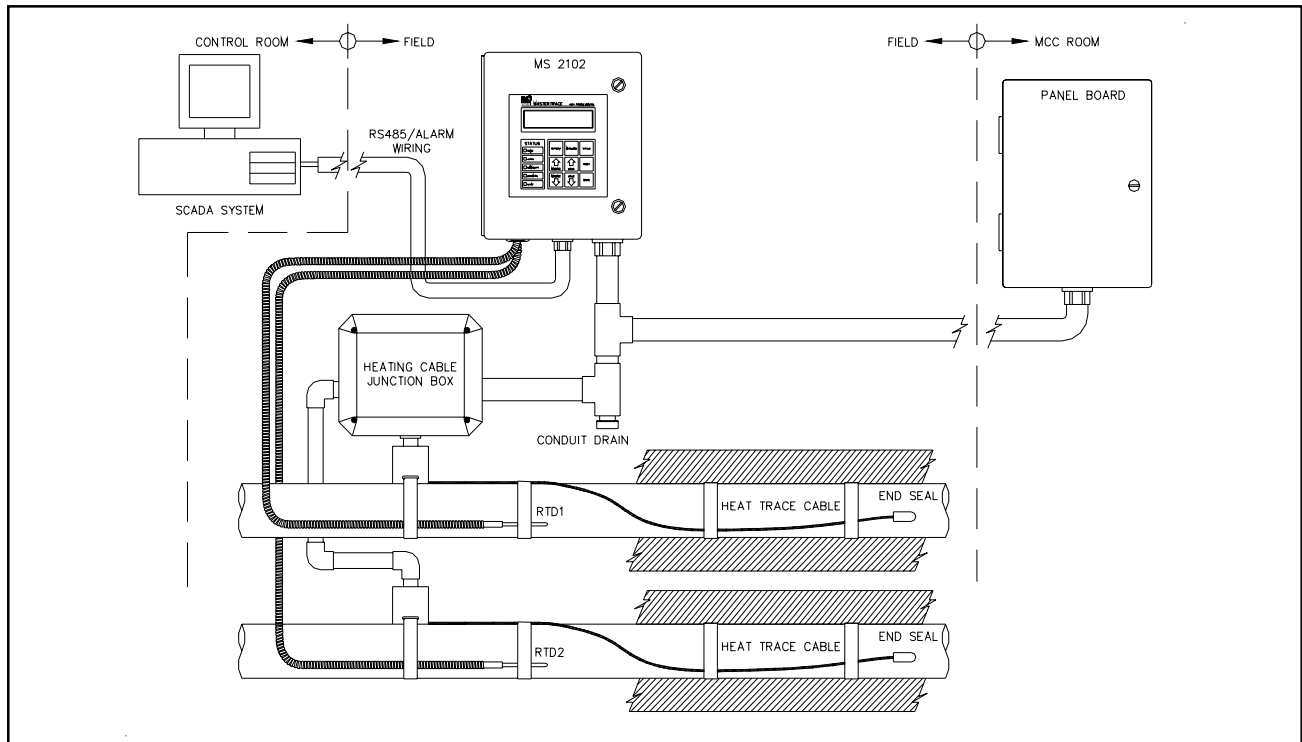

**Specifications<sup>1</sup>**

**Models:** MS-2102, MS-2102-E3, MS-2102-BAC, MS-2102-BAC1, MS-2102-E3-BAC, MS-2102-E3-BAC1, MS-2102-ETH, MS-2102-ETH1, MS-2102-E3-ETH, MS-2102-E3-ETH1

**Temperature Input**

Range: -50 to +500°C (-58 to 932°F)  
 Accuracy: ±2°C  
 Repeatability: ±1°C  
 RTD: Two, 100 ohm platinum, 3-wire RTD  
 20 ohms maximum lead resistance

**Heater Switching**

Configuration: Two circuit, single-pole, one SCR per circuit, 800 amp 1 cycle inrush  
 Ratings: 85-280Vac, 30A continuous  
 Line Frequency: 50 or 60Hz  
 Current Measurement: 0.1 to 30A 3%±0.2A  
 GF Measurement: 10 to 1000mA 5%±2mA  
 Voltage Measurement: 0 to 300Vac 3%±2V (only for heater 1)

**Control Power**

Power Requirement: Control power from heater 1 voltage 85-280VAC, 10VA max  
 Protection: Control power from heater 1 voltage protected by 2A fuse  
 MOV transient protection

**Communication**

Port: 1 Serial network connection  
 Type: RS485  
 Protocol: Modbus® RTU.  
 Transmission Rate: 600,1200, 2400, 4800, 9600 baud.  
 Interconnect: 2-wire, shielded, twisted pair.  
 Highway Distance: 4,000 feet without repeater.  
 Modules per Highway: 32 Control Modules.

**BACnet/IP Ethernet Communication**

Models: Models with options BAC/BAC1  
 Gateway: 1 configured & assembled MasterTrace Modbus to BACnet/IP gateway, separated from MS-2102 module  
 Serial Connection: To be connected to serial ports @ 9600 baud on modules via RS485 cable  
 Ethernet Connection: To be connected to Ethernet network via Ethernet cable  
 Enclosure: FRP enclosure with option BAC1 only

**MODBUS TCP Ethernet Communication**

Models: Models with options ETH/ETH1  
 Gateway: 1 configured & assembled MasterTrace Modbus to Modbus TCP gateway, separated from MS-2102 module  
 Serial Connection: To be connected to serial ports @ 1200~9600 baud on modules via RS485 cable  
 Ethernet Connection: To be connected to Ethernet network via Ethernet cable  
 Enclosure: FRP enclosure with option ETH1 only

**Measured Values**

Temperature: -50 to 500°C (-58 to 932°F)  
 Minimum Temperature: -50 to 500°C (-58 to 932°F)  
 Maximum Temperature: -50 to 500°C (-58 to 932°F)  
 Heater Current: 0.1 to 30A  
 Ground Fault Current: 10 to 1000mA  
 Min. Heater Voltage: 85 to 300Vac  
 Max. Heater Voltage: 85 to 300Vac  
 Power Consumption: 0 to 1,000 MWh  
 Operating Cost: 0 to \$1,000,000.00

**User Interface**

Display: 16-character x 2-line LCD display  
 Keypad: 9 tactile keys, polyester faceplate  
 - Setpoint, measured, status  
 - Message Up, Message Down  
 - Value Up, Value Down, Reset, Store

Contrast: Adjustable by potentiometer  
 Panel Indicators: Power on, Heater on, Communication active, System fail, Process alarm  
 Security: Controller parameters switch-protected

**Environment**

Approvals: CSA C/US, Class I, Div. 2, Groups A, B, C, D; Class I, Zone 2, Groups IIC; Class II, Div. 2, Groups F & G; Class III  
 Operating Temperature: -40°C to +50°C  
 Conformal Coating: Boards conformal coated for hostile environments

**Enclosure**

Type: Models with option E3: Nema-4X stainless steel, painted black  
 Models without option E3: Nema-4X steel, painted black  
 Size: 10"Hx8"Wx6"D  
 Features: Quick release latches to open door  
 Flat aluminum plate to act as heatsink and mounting flange for mounting on Uni-Strut.  
 One 3/4" conduit knockout for power and three 1/2" conduit knockouts for RTD and signal wiring.

**Alarm Output**

Alarm: Programmable for NO or NC contact  
 One Mechanical (dry) contact  
 Alarm Rating: Mechanical contact: 30Vdc/100mA, 120Vac/0.52A, 62.5W Max  
 Alarm Output: LED Indicator: 5Vdc/50mA

**Alarm Function**

Temperature: High Temp Alarm, Low Temp Alarm  
 Current: Low Current Alarm, High Current Alarm  
 Ground Fault Current: Ground Fault Current Alarm  
 Ground Fault Current Trip  
 Voltage: Low Voltage Alarm  
 Hardware: Self-Check Failure, Relay Failure, RTD Open, RTD Short

**User-Definable Options**

Heater Status: Enable or Disable  
 Heater Name or Tag: 16 Character Alphanumeric  
 Temperature Units: °C or °F  
 Proportional Control: on or off  
 Deadband: 1 to 50°C (2 to 90°F)  
 Power Limit: 0.1 to 30A, off  
 TraceCheck: 1 to 24hrs, off  
 Temperature Setpoint: -50 to 500°C (-58 to 932°F), off, none  
 High Temp Alarm: -50 to 500°C (-58 to 932°F), off  
 Low Temp Alarm: -50 to 500°C (-58 to 932°F), off  
 High Current Alarm: 0.1 to 30A, off  
 Low Current Alarm: 0.1 to 30A, off  
 Ground Fault Alarm: 10 to 1000mA, off  
 Ground Fault Trip: 10 to 1000mA, off  
 Low Voltage Alarm: 85V to 300V, off  
 RTD Fail-safe: Heater On or Heater Off  
 Override: On or Off  
 Alarm Contacts: NO or NC for mechanical contact  
 Alarm Light: Alarm on, Alarm off, Flash during alarm then on, Flash during alarm then off

**Ground Fault**

Maximum Trip Time: 7.4 seconds

**1. This is a precise specification for MS2102 controller. For MS2102 panels, there could be some variations.**

## Summary of Features

### Inputs

- 2-RTD Sensors, one per circuit
- 1-Override

### Monitoring

- RTD Temperatures
- Heater Current
- Heater Voltage
- GF Current

### Alarms

- Low and High Current
- Low and High Temperatures
- GF Alarm
- GF Trip
- Relay Failure
- Sensor Failure
- Self-Test Failure

### Outputs

- 1-Mechanical (dry) Contact
- 1-LED Alarm Indicator

### Statistics

- Minimum and Maximum Temperatures
- Maximum Current
- Maximum Ground Fault
- Energy (MWh)
- Energy Cost

### Control

- Temperature (On/Off- Deadband)
- Temperature -Proportional
- Power Limiting

### Early Warning (TraceCheck)

- Low and High Current
- GF Alarm
- GF Trip

### Communications

- 1-RS485
- Modbus Protocol

### Environment

- CSA Certified for Hazardous Locations
- Weatherproof, NEMA-4X Enclosure
- -40°C to +50°C Operating Temperature Range (LCD: -20°C to +50°C)

### User Interface



- 32 Character LCD Display
- LED Indicators on Faceplate
- Clear, English Language Messages
- Intuitive Message Structure
- Tactile Keys
- Access Security

## Using This Manual

Detailed information relating to switch and output ratings, accuracy and so forth are detailed in *Chapter 1 Specifications*. *Chapter 2 Installation* discusses important mounting and wiring issues for reliable operation. *Chapter 3 Getting Started* provides a step-by-step tutorial for a heat trace application. The remainder of this manual should be read and kept for reference to provide the maximum benefit of the MS-2102.

## Conventions

The following conventions are used in this manual.

-  User Changeable Values
-  Retrieved Data
- [ ] Key Press

## Shipping Content

MS-2102 Heat Trace Controller  
MS-2102 Instruction Manual with Warranty Card

**Theory of Operation**

Controller functions are controlled by a microprocessor that measures all analog signals and logic inputs, control heater outputs and alarm contacts, and reads all user input including communications and outputs to the faceplate display and LEDs. Consult the hardware block diagram in figure 1.5 for details. The remainder of this chapter describes the algorithms and operation of some of the controller functions.

**RTD Sensing**

An RTD changes its resistance in a precision relationship to temperature. This resistance is sensed by passing a constant current through the RTD and measuring the resulting voltage across the RTD (resistance = voltage/current). The voltage appearing across RTD1 terminals 6-8 (designated to heater 1) or RTD2 (designated to heater 2) terminals 10-12 also includes the resistance of the inter-connecting wiring to the RTD, which varies with wire length, size and ambient temperature. By using a three-wire sensing scheme and a lead resistance compensation circuit, the lead resistance is cancelled out to give a voltage proportional to the true RTD sensor temperature.

RTDs respond in a known but non-linear fashion to temperature, which if uncorrected could lead to significant errors over the temperature range of the controller. Consequently, some means are needed to convert the input voltage to a linear and useful range. The CPU applies gain, offset and non-linearity corrections through a linearization algorithm.

**Current, Ground Fault and Voltage Sensing**

Current transformers and high impedance voltage dividers are used to scale-down the incoming heater current, ground fault current and voltage. All three signals are then passed through a full wave rectifier and filter to obtain a DC signal. The DC signals are then converted to digital values by a 10 bit A/D converter before finally being passed on to the CPU for analysis.

Each of the three DC signals are sampled 300 times with zero cross synchronization so that the sampling covers an exact span of ten power cycles. This is to ensure that heater current values are consistently measured when the heater output cycle is modulated by the power limit and proportional control functions.

**Power Limit**

The power limit function allows the heater to operate below its rated power by cycle modulation. Cycle modulation is accomplished by controlling the integral number power cycles into the heater over a periodic time frame. The MS-2102 uses a ten cycle time frame. The integral number of power cycles per time frame is called a *duty cycle*. With a ten cycle time frame, there are ten duty cycles possible. For each duty cycle, there is a fixed pattern that defines the number of power cycles in which the heater is on and off. This is shown in figure 1.2:

Figure 1.2 Cycle Modulation - 10 Cycle Frame

DUTY CYCLE	CYCLE ON	CYCLE OFF	SWITCHING PATTERN
0%	0	10	
10%	1	9	
20%	2	8	
30%	3	7	
40%	4	6	
50%	5	5	
60%	6	4	
70%	7	3	
80%	8	2	
90%	9	1	
100%	10	0	

Cycle modulating the current through the heater has the effect of turning the heater on and off rapidly and therefore, power output is reduced in the long run. Since the switching is zero-cross controlled, the controller knows exactly when power cycles start and finish. Zero-cross switching also helps reduce power harmonics that generate unnecessary interference.

The heater current (average current) measured by the controller while cycle modulation is in effect may be approximated as follows:

Heater Current at 100% x Duty Cycle = Average Current

When power limit is enabled, a power limit current is set by the user. This is essentially the desired average current. The power limit control algorithm ensures that the actual current will not exceed the power limit setting while optimizing the maximum duty cycle possible. When the average current exceeds the power limit setting, the duty cycle is reduced by 10%. When the average current is below the power limit setting, the duty cycle is increased by 10%. Before the algorithm increases or decreases the duty cycle, the controller waits until the heater current has reached steady-state at the current duty cycle setting. If the heater is initially off and the controller calls for heat, the duty cycle starts at zero and increases by 10% increments until it reaches a steady-state value. This ramping up effect provides a current-driven softstart whenever the controller calls for heat.

**Proportional Control**

Unlike on/off control where the heater is fully on or off, proportional control can partially turn on the heater. The heater output is proportional to the difference between actual temperature and heater setpoint. The relationship is expressed as follows:

(actual temperature – heater setpoint) x k = heater output  
 where k is the proportional gain

To partially turn on the heater, the proportional control function uses cycle modulation in the power limit function. By incorporating cycle modulation into the proportional control equation, the algorithm is expressed using the Equation 1.

The deadband factor  $DB(t)$  is a time constant that determines the slope of change of the proposed heater on duty cycle with the temperature difference. It is adjusted between 1 to 10 each hour to minimize the difference between the measured temperature and the temperature

$$\begin{aligned}
 d(t) &= 0 && \text{if} && e(t) \leq 0 \\
 d(t) &= \frac{e(t)}{DB(t)} && \text{if} && 0 < e(t) < DB(t) \\
 d(t) &= 1 && \text{if} && e(t) \geq DB(t)
 \end{aligned} \tag{1}$$

Where  $d(t)$  = duty cycle  
 $DB(t)$  = deadband factor (in °C/duty cycle)  
 $T_s$  = heater setpoint temperature (°C)  
 $T(t)$  = heater temperature (°C)  
 $e(t)$  =  $T_s - T(t) = \Delta T$  (°C)  
 $t$  = time in seconds

setpoint. Every hour after power up, the controller calculates the absolute values of the temperature differences  $e(t)$  and sums them during the hour. Then the total absolute temperature difference is divided by the number of temperature readings taken during the hour. The result is called the Average Absolute Temperature Difference (AATD) for the hour. If current AATD is smaller than the AATD in the previous hour, the deadband factor will be increased or decreased in the same direction. If current AATD is larger than the AATD in the previous hour, the deadband factor will be increased or decreased in the reversed direction. At steady state, the deadband factor used will fluctuate around a optimum value.

Figure 1.3 shows the relationship between the proposed heater on duty cycle and the temperature difference for different deadband factors used.

Figure 1.3 Proportional Control Duty Cycle vs. Temperature Difference

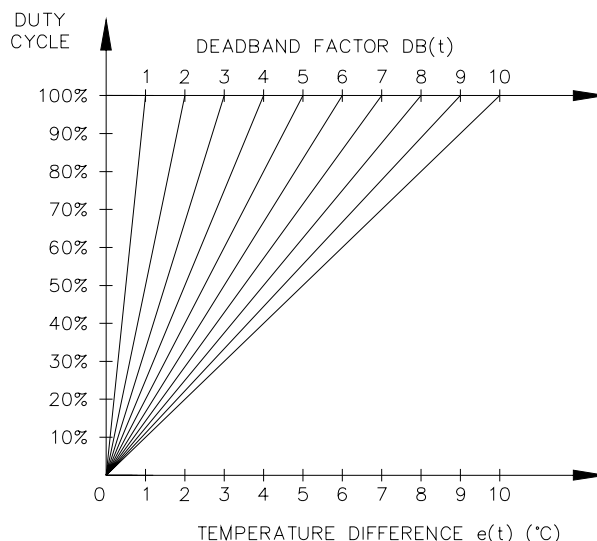

### On/Off Control with Deadband

The default control mode of the controller is deadband control or simply on/off control with the proportional control setting turned off. On/off control without deadband (that is deadband set to 0 C° or 0 F°; note that these units denote the temperature differential with “°” placed to the right of the unit) means that the heater turns on when actual temperature is below setpoint and turns off when above setpoint. However, this causes oscillations when the actual temperature is very close to setpoint. To eliminate oscillations, hysteresis is applied to the on/off control by a deadband value. The on/off control with deadband operation is described by the hysteresis curve in figure 1.4. Assume that actual temperature is well below (setpoint - deadband setting), the controller calls for heat. As the actual temperature rises, the controller continues to call for heat until the actual temperature has reached (setpoint + deadband setting). The controller no longer calls for heat and the heater is off. As the actual temperature cools, the controller does not call for heat until the actual temperature reaches (setpoint - deadband setting). The hysteresis effect is controlled by the momentum of the actual temperature rather than the temperature value itself.

Figure 1.4 On/Off Control with Deadband

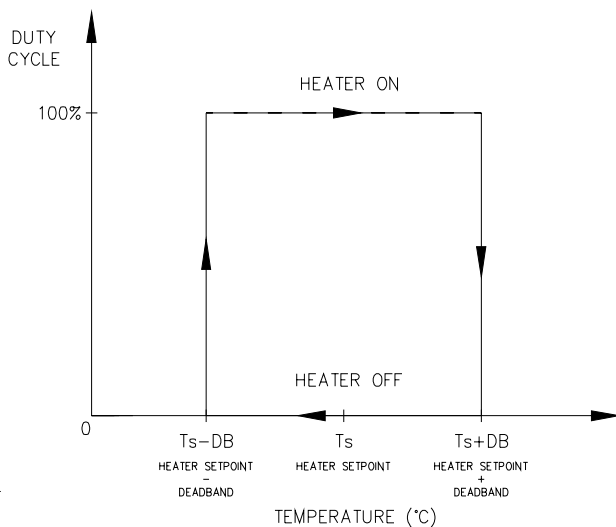
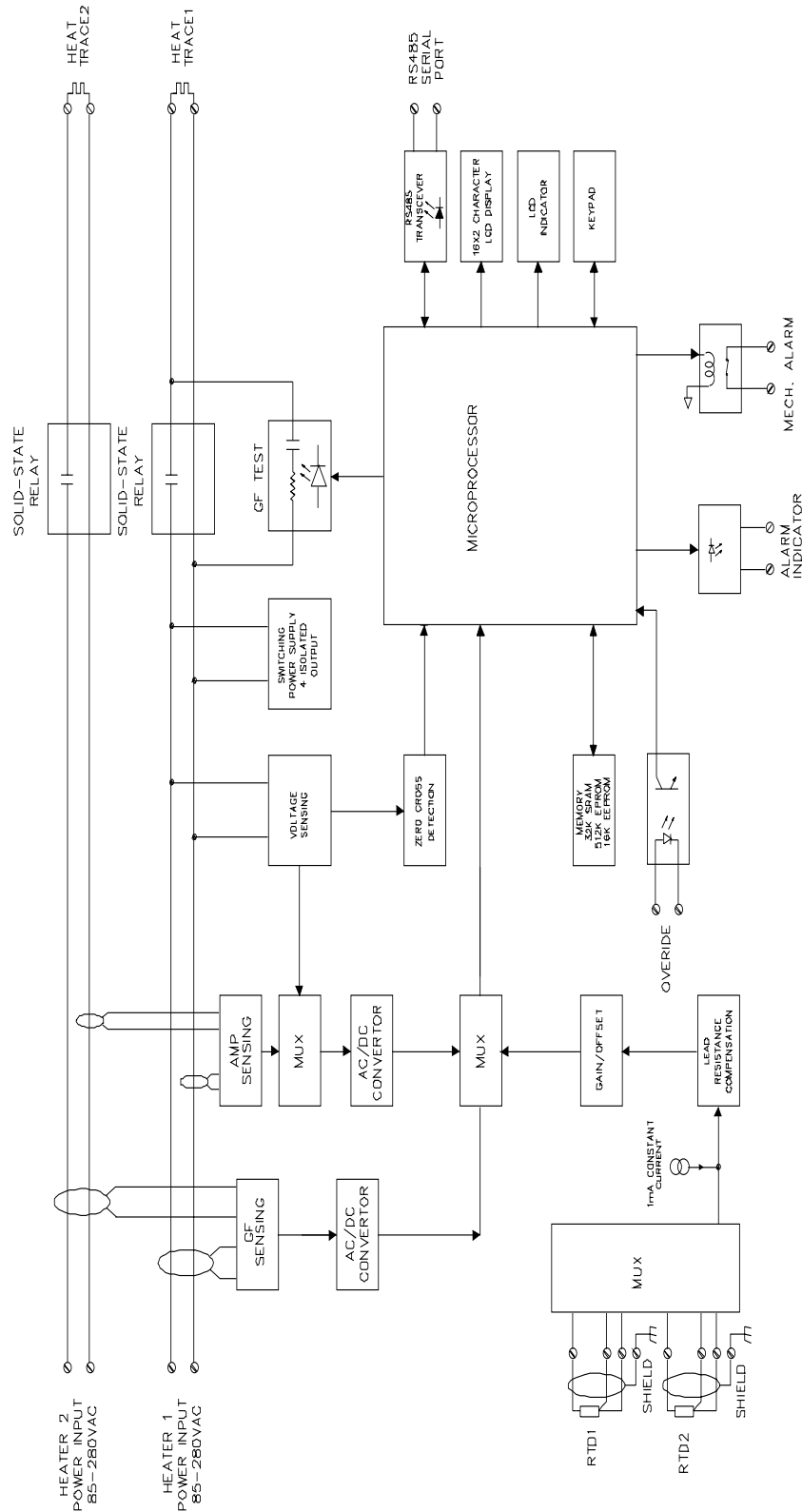

Figure 1.5 Hardware Block Diagram



### Unpacking the Controller

Check the shipping cartons for damage, or other signs of rough handling or abuse. If damaged, notify the shipping carrier at once.

Carefully remove the MS-2102 from the shipping box.

Save the packing materials in case the unit needs to be transported at a later date.

Inspect face plate for damage and check electronics for loose wiring or damage. Report any damage to the carrier at once.

### Control Module

See *Figure 2.1 Main Board Layout* and *Figure 2.2 Power Board Layout* to locate the following:

- **S1** Address Enable: When the switch is set to **DIS**, the Module Number cannot be changed from a master on the data highway. When set to **EN**, the Module Number can be changed for the next ten minutes from a master on the data highway. During this time the ADDRESS ENABLE light is **on**.
- **S2** Program Enable: When the switch is set to **DIS**, programming via keypad is disabled; setpoints and configuration cannot be changed. When set to **EN**, programming is allowed.
- **S3** RS485-120: When the jumper is set to **IN**, the RS-485 line is terminated by a 120 ohm resistor. Only the last Control Module on the data highway should be set to **IN**.

Terminals: Refer to *Figure 2.7 Typical Wiring Diagram*, for power, heater and RTD field connections.

- **T1** Alarm Contact: The mechanical alarm output is rated 30Vdc/100mA, 120Vac/0.52A, 62.5W Max. Without power, the contact is open. With power, it is configurable for normally open or closed.
- **T2** Alarm Light Output: The output is configurable for normally open, closed or flash. Output is rated 5 Vdc @ 50 mA for an LED type lamp (terminals 18+ and 19-).
- **T3** Mater Override Input: Only those heaters which are programmed with Mater Override set to **on** are affected by the Master Override Input. When the terminals are open, all Master Override Enabled heaters are forced off. When the terminals are closed, all Master Override Enabled heaters are controlled by their individual RTDs unless their Heater Setpoints are set to **OFF**. In this case, the heaters are turned on. The logic of this input allows either ambient temperature override or load shedding on all or selected heaters. (terminals 24+ and 25-).
- **T4** RTD1 and RTD2 Inputs: 3 wire RTD input. Ground terminal connects to shield or case. Lead resistance compensated. (terminals 6-13).

- **T5** Earth Ground: (terminal 1).
- **T6** Heater 1 Power Input: 85-280Vac/30A max continuous ( terminals 2 and 3).
- **T7** Heater 1 Power Output: 85-280Vac/30A max continuous ( terminals 4 and 5).
- **T8** Heater 2 Power Input: 85-280Vac/30A max continuous ( terminals 26 and 27).
- **T9** Heater 2 Power Output: 85-280Vac/30A max continuous ( terminals 28 and 29).
- **T10** Safety Ground: Terminate to ground stud. Termination of safety ground is required for transient protection circuit on RTD inputs and RS485 serial port to operate properly (terminal 14).
- **T11** Extra A/D Inputs/Output: Terminals 22 (POUT) and 23 (PIN1) are the output (+12Vdc) and input (4-20mA dc) connections to the 1<sup>st</sup> 4-20mA analog signal transmitter. Terminals 22 (POUT) and 24 (PIN2) are the output (+12Vdc) and input (4-20mA dc) connections to the 2<sup>nd</sup> 4-20mA analog signal transmitter.

#### Status Lights:

- **L1** Power: Light is on when control power is present.
- **L2** Address Enable: Light is on when controller is in **Address Enable** mode. Light must be on to allow the Module Number to be changed from a master on the data highway.
- **L3** Transmit: Flashes when data is being transmitted from the serial port to the data highway.
- **L4** Receive: Flashes when data is being received at the serial port from the data highway.
- **L5** Override: Light is on when the Override Input terminals are shorted.

#### Communication Ports:

- **C1** Interface to Main/Power Board: Connector to interconnect power and main board via ribbon cable.
- **C2** Serial Port 1: Connection to an RS-485 data highway via a 2-conductor, shielded, twisted pair cable. Maximum Cable length with 32 devices without repeater is 4,000 feet. ( terminals 15+, 16-,17 SHD).



**Warning - The ground fault trip function is intended for equipment protection only and should not be used in place of ground fault protection for personnel protection where this is required.**

Figure 2.1 Main Board Layout

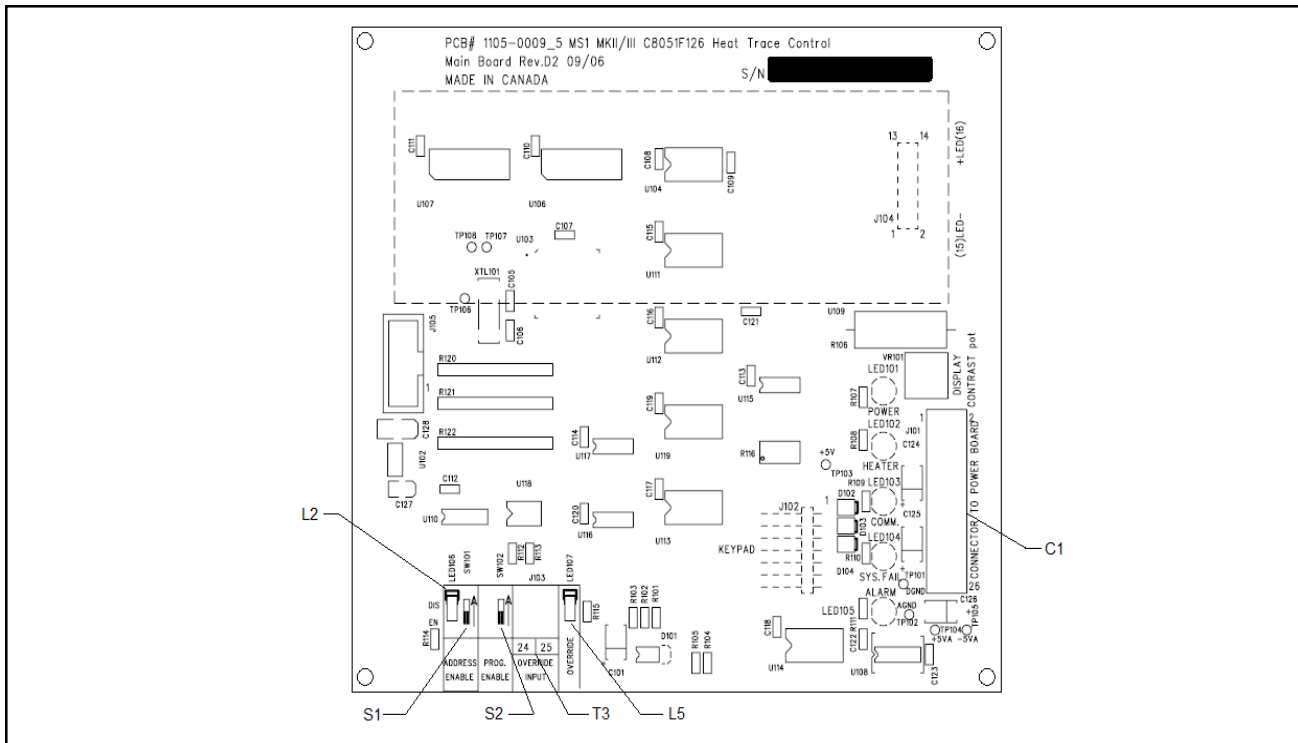
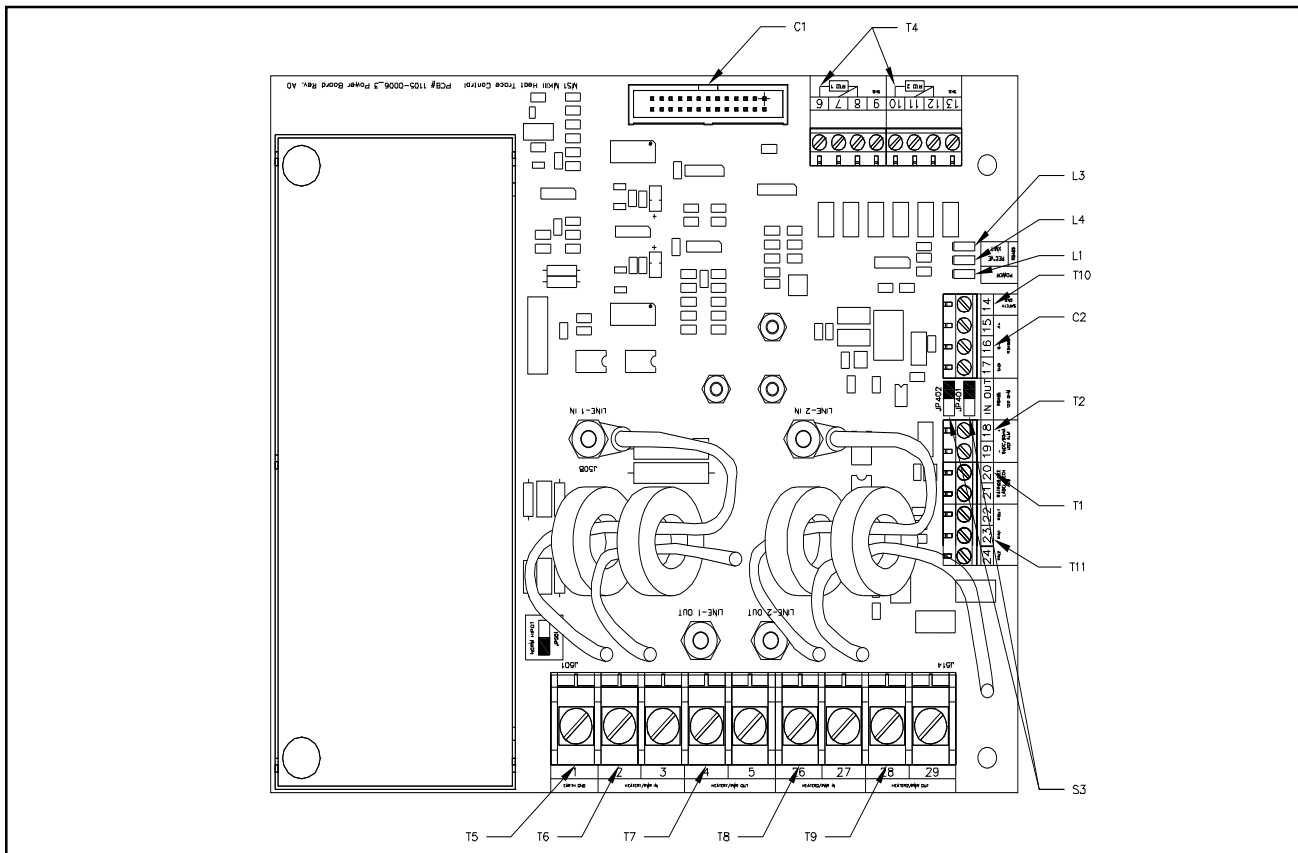

Figure 2.2 Power Board Layout



### Mounting the Controller

Mount the control panel with Unistrut brackets using 1/2" bolts. The Unistrut (or equivalent) mounting allows air circulation to cool the heat-sink. This is important to ensure proper operation of the MS-2102. For optimum readability, mount with the display at eye level and not in direct sunlight. Mounting dimensions are shown in *Figure 2.6*.

### Wire Sizing



**Wiring methods should comply with Canadian Electrical or National Electrical Code and local codes. Power and signal wires should not be run in the same conduit system. Wiring should be rated at least 90 °C.**

Wire Size (AWG)	Current Load (A)	Max. Ambient Temperature (°C)
6	30	50
8	30	40
10	24	50
12	16	50

### Conduit and Cabling

The MS-2102 comes with one 3/4" and three 1/2" conduit knockouts located on the bottom of the enclosure. Conduit hubs should be NEMA-4X rated, such as T&B H050-0.5 and H075-0.75 or Myers equivalent, to maintain a watertight seal. Unused knockouts should be sealed using NEMA-4X rated seals.

### Power Wiring

The power input terminals 2 & 3 supply power to both heater 1 and controller, while power input terminals 26 & 27 supply power to heater 2. Size power input wires appropriately to the breaker size and maximum ambient operating temperatures. Maximum breaker size is 30A. Connect power wires to input terminals 2 & 3, and 26 & 27. See *Figure 2.7*.



**The supply voltage must be within the power supply range of 85-280Vac and rated voltage range of the heat trace cable.**

### Heater Wiring

Connect the two heating cables wiring to terminals 4 & 5, and 28 & 29, respectively. See *Figure 2.7*. If the heating cable has a braid, it should be terminated to the ground stud using a ring terminal suitable for #10 stud.



**Wiring methods must conform to Class I, Division 2 or Class I, Zone 2 requirements.**

### Ground Connection

Connect the controller grounding stud directly to a ground bus using the shortest, practical path. Use a tinned copper, braided bonding cable such as Belden 8660. As a guideline, the ground cables should be minimum 96 strands, number 34 AWG each.

The grounding is not only a safety requirement but is necessary for the input transient protectors or the RTD and communication inputs to work properly. The transient protection network is grounded through terminal 14, safety ground, which is bonded to the chassis ground stud. To install the ground connection, remove the outside nut, washer and #10 ring lug provided on the ground stud. Crimp the ground cable onto the ring lug and re-assemble onto the ground stud using the washer and nut.

*Figure 2.3* Ground Connection

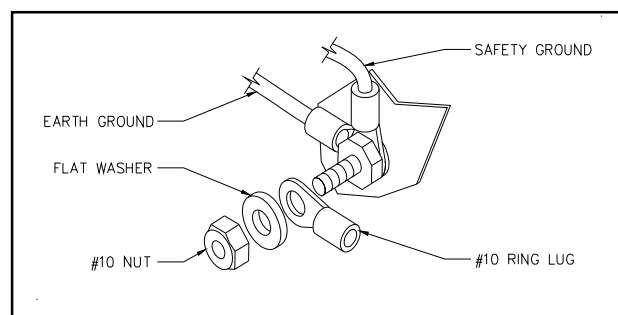

### RTD Sensor Wiring

RTD sensors should be 3-wire, 100 ohm, platinum to DIN EN 60751 standard. Mount the RTD element on the pipe, away from the heat trace and 30° to 45° from the bottom of the pipe. The total circuit resistance per conductor from the RTD to the control panel must be less than 10 ohm. Exceeding this resistance will result in a non-linear temperature measurement. Belden cable 8770 or equivalent allows RTDs to be placed up to 1,000 feet from the control panel. Complete all RTD wiring according to *Figure 2.7 Typical Wiring Diagram*.



**The RTD probe is delicate and should not be bent or used as a tool to puncture insulation.**

*Figure 2.4* RTD Mounting

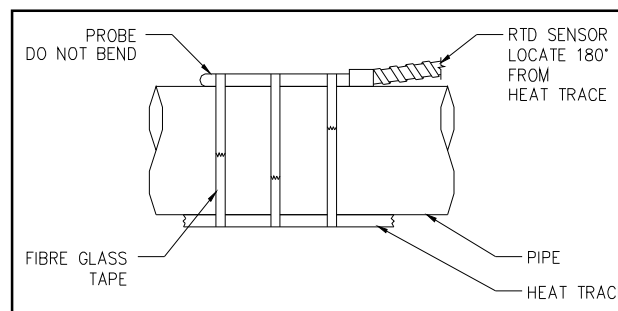

You must install the RTD sensor on the pipe surface or thermal well before the pipe insulation to ensure proper thermal contact. The RTD position should be 180° from the electric heat trace cable which is the coldest spot of the pipe. The RTD sensor may be secured to the pipe by fiber-glass tape. If additional wiring is required for the RTD, shielded 3-lead wire sized 18 or 20AWG must be used for the RTD sensor to minimize the effects of noise pickup. A typical RTD installation is shown in *Figure 2.4*.

**Communication Wiring**

The MS-2102 is equipped with a communication port that provides continuous monitoring and control from a remote computer, SCADA system or PLC. Communications protocol is Modicon Modbus as discussed in the communications chapter.

Communication is RS-485 mode where data transmission and reception are done over a single twisted pair with transmit and receive data alternating over the same pair of wires.

Shielded twisted pair such as Belden cable 9841 or equivalent is recommended to minimize error from noise. You must observe polarity. For each MS-2102 controller, you must connect A+ terminals together and B- terminals together. The shield terminal (labelled SHD) connect to shield wire of the cable.

To avoid loop currents, the shield should be grounded at one point only. Connect between controllers in daisy-chain fashion. The total length of this daisy-chain should not exceed 4,000 feet. The maximum number of devices connected is 32 to avoid exceeding driver capability. You can use commercially available repeaters to increase the

number of devices over 32. Avoid star or stub connections.

Terminate the first and last device in the daisy-chain loop. Each controller is equipped with a termination jumper as shown in *Figure 2.2*.

The controller comes unterminated from the factory (JP401 and JP402 in **OUT** position). If the controller is the first or last device, it can be terminated by moving the two jumpers (JP401 and JP402) to the **IN** position.

The communication port is powered by an isolated power supply with opto-coupled data interface to eliminate noise coupling. In addition, surge protection devices are employed at the front end of the port to protect against lightning strikes and ground surge currents. These may cause large, momentary voltage differences between devices on the data highway.

**Alarm Wiring**

The MS-2102 has one passive (mechanical) alarm contact and one active alarm output for driving an LED alarm indicator. Without power, the alarm contact is open. With power, it is software configurable for normally open or closed. The alarm LED output is software configurable for alarm on, alarm off or flash during alarm. Refer to *Figure 2.7* for alarm output terminals.

The mechanical (dry) alarm output is rated 30Vdc/100mA, 120Vac/0.52A, 62.5W Max.

The alarm LED output is rated 5Vdc, 50mA. It can drive a 6Vdc LED indicator. Alarm output is designed for interface to annunciator, panels, PLC or DCS.

*Figure 2.5* Communication Wiring

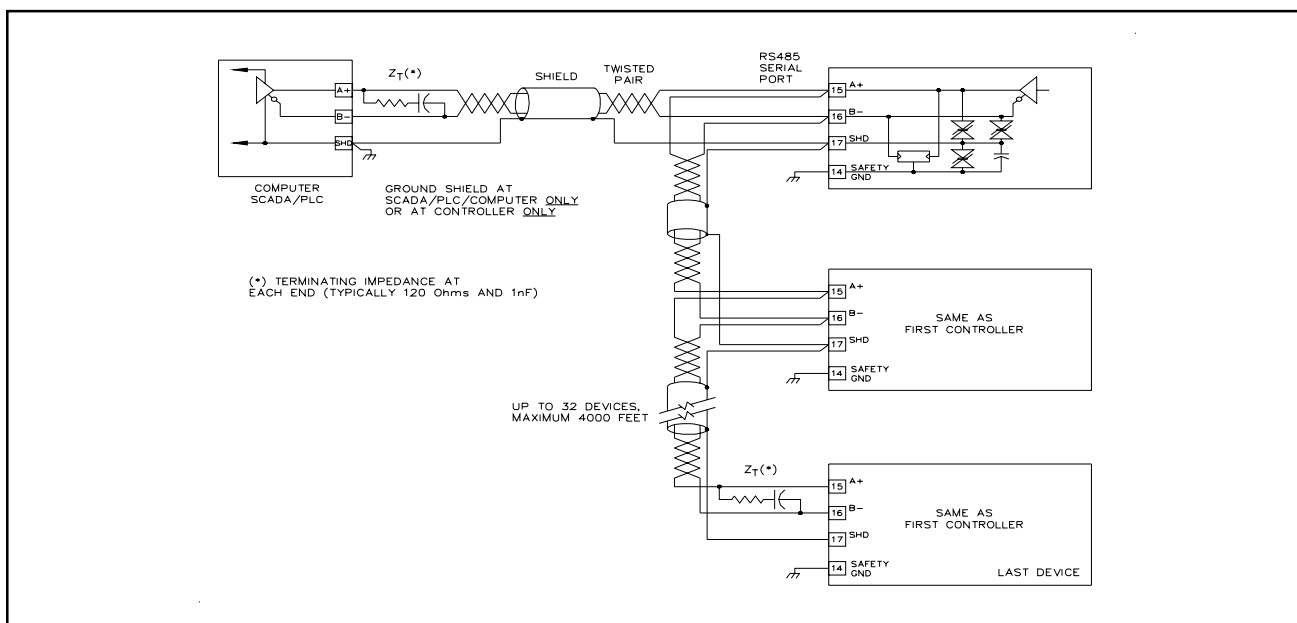

Figure 2.6 Mounting Dimensions

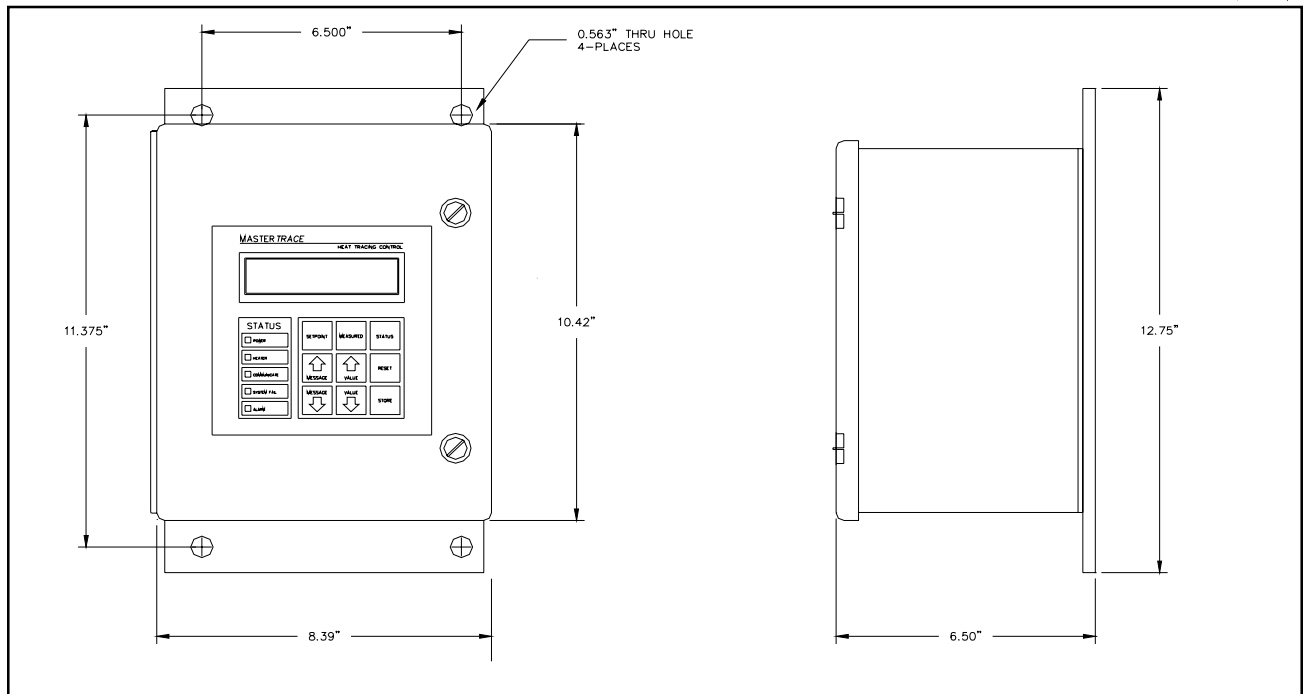
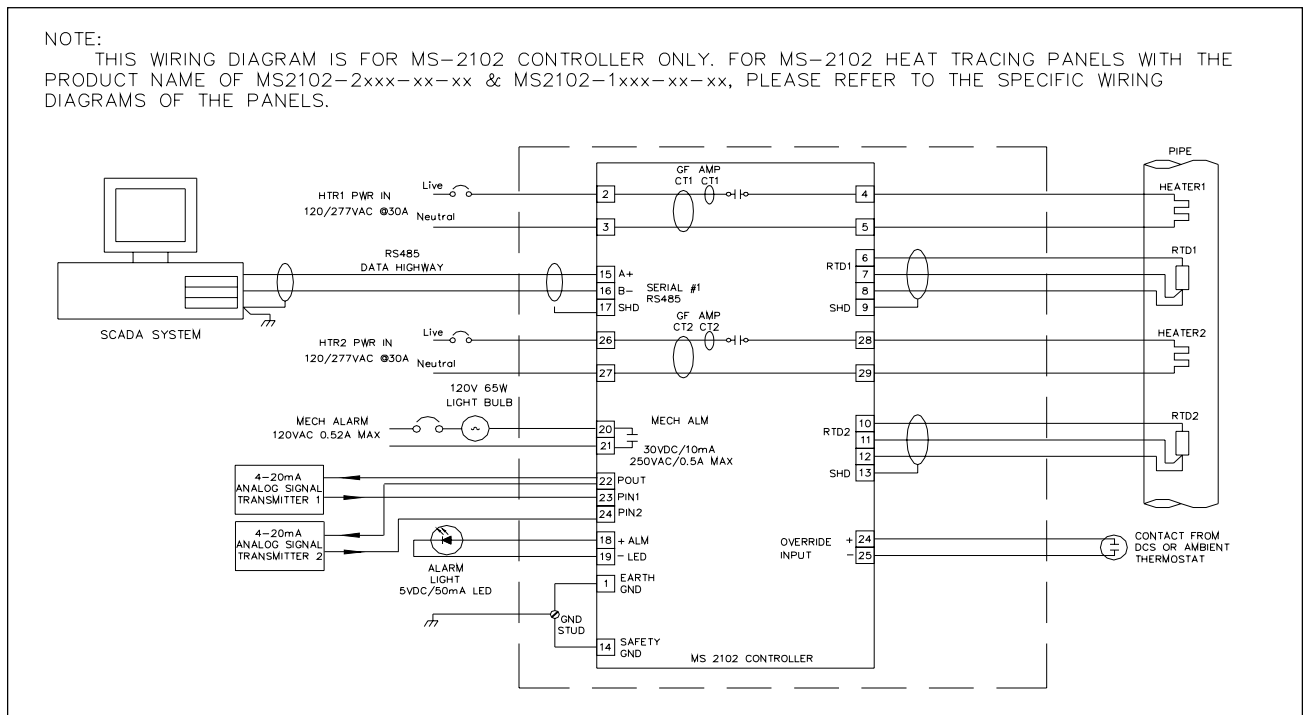

Figure 2.7 Typical Wiring Diagram



**Warning - Explosion Hazard - Substitution of components may impair suitability for Class 1, Division 2 or Class 1, Zone 2.**



**Warning - Explosion Hazard - Do not disconnect equipment unless power has been switched off or the area is known to be non-hazardous.**

**Introduction**

The MS-2102 has many features that provide trouble-free operation of heat tracing installations.

An example is presented to illustrate MS-2102 setup and operation on a specific installation. MS-2102 is easy to program and setting up a unit to your specific requirements should be straight forward.

Example: Heater 1-2 will be programmed as:

**Configuration**

- 1) The module number is 1 and the heater 2 of this module is used to control a heavy feed line.
- 2) Mineral insulated (MI) cable is used for the heater.
- 3) Normally open alarm contact to remote programmable control
- 4) Northern climate installation outdoors.  
Operating temperatures: -40~50 °C (LCD: -20~50 °C)  
NEMA-4X weatherproof enclosure.

Setpoint	Required	Range
Fluid maintain temperature	50 C	-50 to 500 F/off /none
Low temperature alarm	35 C	-50 to 500 C/off
High temperature alarm	no alarm	-50 to 500 C/off
Nominal heater current	5 amps	0.0 to 30.0A
Nominal heater voltage	115 VAC	100 to 300 Vac
Ground fault trip current	30 mA	10 to 1000mA /off
Ground fault alarm current	20 mA	10 to 1000mA /off
System exercise time interval	8 hours	1-24/off
Cost per Kilowatt hour	\$0.06	\$0.01-\$0.50
Heater name	HEAVY OIL LINE	16 characters

- Install and commission the control in the following order:
- STEP 1: Selecting the heater
  - STEP 2: Enabling the heater
  - STEP 3: Entering setpoints
  - STEP 4: Testing heater and alarms
  - STEP 5: Monitoring system status

**Selecting the Heater**

To select the heater circuit,

- 1. Press [SETPOINTS] once to access the Setpoints Operating Values group of messages.
- 2. Press [MESSAGE ↵] until the following message appears:



- 3. Within the message “SELECT HT M-N”, M is the module number and N is the heater circuit number within the control module.
- 4. Press [VALUE ↵] key to have “SELECT HT 1-2” displayed.
- 5. Press [STORE] key to select the heater 1-2.

**Enabling the Heater**

To enable the heater circuit,

- 1. Press [SETPOINTS] once to access the Setpoints Operating Values group of messages.
- 2. Press [MESSAGE ↵] until the following message appears:



- 3. Press [VALUE ] or [VALUE ↵] keys to toggle Heater Enabled between **YES** and **NO**.
- 4. When **YES** is displayed, press [STORE]. Enabling the Heater

**Entering Setpoints**

Accessing the Program: Since the heater control display and keypad are normally accessible to passers-by who may wish to read measured values, a program disable feature is used to prevent accidental changes to the setpoints. So before any setpoints can be entered, the PROGRAM ENABLE dip switch (located on the bottom of the board behind the enclosure door) must be set in the ENABLE position.

When programming is complete, set the PROGRAM ENABLE dip switch to **DISABLE** to prevent accidental changes to the setpoint.

If you try to store a setpoint without the dip switch in the **ENABLE** setting, the setpoint will not be saved and this message will flash on the screen:



Now that the MS-2102 control is ready for programming. For further information about the organization of all the messages or for details on the range and application of each message see *Chapter 6 Setpoint Values*. It is not necessary to enter setpoints in any particular order and any setpoint can be changed later.

Entering Temperature Units °C/°F: Temperature values can be displayed in degrees Celsius or Fahrenheit. To enter values in preferred units, enter this selection first.

To enter temperature units,

1. Press [SETPOINTS] 3 times for System Setup mode and [MESSAGE ↵] key until the following message is displayed:

TEMPERATURE  
UNITS: Celsius

2. Press [VALUE ↑] or [VALUE ↓] to toggle selection between Celsius and Fahrenheit.
3. When Celsius is displayed press [STORE]. A brief message appears:

SETPOINT  
STORED

Then the message reverts back to the previously entered value for verification. If instead you get the message:

NOT STORED -  
PROG DISABLED

the PROGRAM ENABLE dip switch has not been set to the ENABLE setting. This must be done to proceed with setpoint programming.

Assuming the setpoint was stored, all values will be displayed in °C. Temperature values can automatically be converted to °F at any time by selecting Fahrenheit using this message.

TEMPERATURE  
UNITS: Celsius

ASSIGNING HEATER NAME: To assist operators in troubleshooting, you can program each heater in the MS-2102 control with a heater name. You can assign up

to 16 characters to the name of a heater.

To assign a heater name,

1. Press [SETPOINTS] twice to enter the Heater Setup group of setpoints.
2. Press the [MESSAGE ↵] key until the heater name message appears:

HTR 1-2 NAME:  
NONAME ✎

Note: The heater default name when MS-2102 is shipped from the factory is “NONAME”.

You can program each letter separately with upper and lower case characters, numbers, space or the special symbols !@#\$%^&\*()?,.,”’;}{. Uppercase characters are generally more legible. For this example the name has arbitrarily been chosen as:

HEAVY OIL LINE

(The cursor appears under the first letter N in “NONAME”).

3. Press and hold down [VALUE ↑] or [VALUE ↓] until the desired letter you want appears above the cursor, then press [STORE].
4. Press [STORE] to save the current letter displayed and advance the cursor to the next letter.

For Example:

H: Press [VALUE ↑] or [VALUE ↓] until H appears. Press [STORE]. The letter H now appears in the first character position and the cursor is under the second character.

E: Press [VALUE ↓] until E appears. Press the [STORE]. The first 2 letters are now HE and the cursor is under character position 3.

HTR 1-2 NAME:  
HENAME ✎

5. Continue entering each letter this way until the complete new name is displayed.
6. With the cursor under the last character position at the right edge of the message screen (blank character), press [STORE] until the cursor is at the end of the line. A brief message will flash:

NAME  
STORED

followed by the new name that has been stored:

HTR 1-2 NAME:  
HEAVYOILLINE

The new heater name is now saved in non-volatile memory and will remain until you change it.

If a character is accidentally entered incorrectly,

1. Either press [RESET] to start over,  
or  
go to the end of the line to save the displayed message with the error.
2. Press [MESSAGE ] or [MESSAGE ↵] to exit and return to the 1<sup>st</sup> character position.
3. Press [STORE] until the cursor is under the incorrect character. Proceed as before until new letters are entered.
4. Press [STORE] to skip over the correct letters until on the last character position.
5. Press [STORE] to save the corrected message.

You can now enter setpoint information for the system configuration and data for the heater. Turn to *Chapter 6 Setpoint Values*. Read the first few pages to see how the messages are organized and get a summary of all setpoints. Skip the latter part of this chapter which gives a detailed description of each message.

#### ENTERING SETPOINT TEMPERATURE:

Set the desired maintained temperature for the fluid in the pipe being traced by this heater temperature setpoint.

To enter the heater setpoint,

1. Press [SETPOINT] once to display this message::

HEATER SETPOINT  
20 °C ✎

2. Press and hold [VALUE ] until 50°C is displayed. If you pass the required value, use [VALUE ↵] to decrease the number displayed.
3. Press [STORE] to save the new value. When a new value is successfully stored a brief acknowledgement message will flash on the screen:

SETPOINT  
STORED

In this example, the temperature at which the control will turn on and supply full system voltage to the

heater is now set to 50 °C.

4. Press [MESSAGE ↵] after each setpoint to access the next setpoint.
5. Hold [VALUE ↑] down until the word OFF appears to defeat any setpoint not required. For example, if a high current alarm is not required, set the value to off. A detailed description of each message is found in *Chapter 6 Setpoint Values*.

#### Testing Heater & Alarms

You can force heater and alarm outputs on using the test mode. Like setpoints, this mode requires that the PROGRAM ENABLE dip switch be set to ENABLE or when you try to store a test value a message will flash:

NOT STORED -  
PROG DISABLED

#### Testing a Heater:

To test operation of a heater, it can temporarily be forced on.

1. Press [SETPOINT] 4 times.
2. Press [MESSAGE ↵] until the message appears:

HEATER TEST  
DISABLED?

3. Press and hold [VALUE ↑] or [VALUE ↵] to set the **ON** time in hours. The range is **DISABLED/1-24 hours/ON-CONTINUOUSLY**. For example, to turn on the heater for one hour, press [VALUE ↑] to display '1 hour' then press [STORE]. The heater will be energized no matter what the heater temperature setpoint is unless there is a ground fault trip. After the selected time period the heater will automatically go off. While the heater is on, the front panel **HEATER ON** indicator will be illuminated. To override the test mode, press [VALUE ↵] until **DISABLE** appears and then store this value. Holding the [VALUE ↑] key until the word **ON CONTINUOUSLY** appears leaves the heater always energized until the MS-2102 controller is manually powered off or until this setpoint is set to **DISABLE**. Consequently, selecting a value of **ON CONTINUOUSLY** should be used with caution since it overrides normal control operation and could lead to excessive heating or waste power if accidentally left on. A warning message appears in the status mode (press status key to enter status mode) whenever a heater or alarm is forced on.

4. Press [STORE] to save the value.
5. With the heater forced on, verify that the expected current is flowing using the actual current message, located in ACTUAL\OPERATING VALUES\HEATER CURRENT. You can use a clamp-on ammeter attached to one of the heater wires to compare readings. With proportional control selected, the readings may differ due to harmonics in the current waveform.

Testing Alarms: The manual alarm setpoint works exactly like the manual heaters setpoint except that it energizes the output alarm and indicator. This setpoint is useful for commissioning a new system or checking alarm circuits. Normally this setpoint will be DISABLED.

**Monitoring System Status**

Now that the MS-2102 controller has been programmed for a specific application, you can check system status. If no keys are pressed for the time specified in DISPLAY TIMEOUT message located in SETPOINT\SYSTEM SETUP\DISPLAY TIMEOUT, the display will automatically go into the default message mode. **System Status** mode is recommended; that is, the display will automatically display all alarms. If desired, you can change this to a specific message later by reprogramming the default message.

Access actual values by pressing [MEASURED]. These are divided into 2 groups. Pressing [MEASURED] once accesses the group of messages that show current values of temperature, current, etc. Pressing [MEASURED] twice displays the statistics data such as minimum/maximum temperature, power consumption, running hours etc. Unlike setpoints, you cannot change actual values using [VALUE ↑], [VALUE ↓] or [STORE].

There is a summary of all Measured Values messages at the beginning of *Chapter 5 Measured Values*.

To view the actual values,

1. Press [MEASURED].
2. Press [MESSAGE ↓] to view each actual value.
3. Continue examining each value of interest by pressing the [MESSAGE ↓] key and referring to *Chapter 5 Actual Values*.

Monitoring Heater Temperature

To monitor the heater temperature,

1. Press [MEASURED] once to display:



This is the temperature value that the controller will use with the heater setpoint to determine the heater output. The 2 heaters in MS-2102 use the actual temperatures of RTD1 & RTD2 as their control temperatures, respectively. If no RTD sensor is connected or a lead is broken the value **RTD OPEN** appears. This is an alarm condition.

When the temperature falls below the heater setpoint, 50 °C in our example, heater 2 in the MS2102 switches on to supply power to the heater circuit. It stays on until the temperature rises above the heater setpoint (50 °C). Once the system has been running for a few hours, the heater temperature should be at or above this setpoint value.

If hot fluid is being pumped through the pipe, the measured temperature may be much higher than the setpoint temperature. But in this case, no power should be supplied to the heater and the **HEATER ON** indicator will be off.

If the heater temperature is less than the minimum display value (-50 °C/-58 °F), the word **RTD SHORT** appears. If the temperature is over the maximum value (+ 500 °C / 932 °F), the word **RTD OPEN** appears. If an abnormal value appears, particularly on a new installation, check that the correct RTD sensor type has been installed (100 OHM platinum DIN EN 60751) and that the three RTD wires are wired to the correct terminals.

Monitoring Actual Current:

To monitor the actual current,

1. Press [MEASURED].
2. Press [MESSAGE ↓] 5 times to display:



This value is the actual measured current of the heater. Resolution is to 0.1 amp over a range of 0.0 to 30.0 amps. Above 30.0 amps the value displayed reads O.L (Overload).

With MI (Mineral Insulated) cable used in this example, it will either be 0.0 if the heater is not energized or a fairly constant current such as 5.0 amps.

Monitoring Ground Fault Current:

Some stray current always flows to ground due to capacitance effects and leakage.

To monitor ground fault current,

1. Press the [MESSAGE ↓] key from the heater voltage message  
or

Press [MEASURED] then [MESSAGE ↵] 6 times to display:

GROUND FAULT  
CURRENT: 15 mA

In this example, any value above 20 mA would cause an alarm and if a ground fault current above 30 mA were detected, MS-2102 would remove power to the heater. If the heater is off, the value displayed would be 0. For values over 15 mA, check the system for insulation leakage problems.

You have now checked all actual values.

Viewing Statistical Data: In addition to actual values that are present, such as current and temperature, the MS-2102 continuously gathers and computes historic information about the heat tracing system to determine cost of operation, utilization, trends etc. This can be quite useful in spotting potential problems or in designing similar systems for other applications. Data is saved indefinitely but you can be clear it anytime.

To view statistical data,

1. Press [MESSAGE ↵] from the actual value messages just displayed to take you to the statistics values group or  
Press [MEASURED] twice to display the first message in this group. Either way displays a brief message to indicate the start of the statistics page followed by the first value message:

MEASURED  
STATISTICS

Since this is a new installation any random data should be cleared.

2. Press [MESSAGE ↵] in this group until the message appears:

RESET STATISTICS:  
yes 

3. Reset statistics for a new measurement interval. The MS-2102 keeps track of when the measurement interval started. See *Chapter 5 Measured Values* for a complete description of how data is gathered and application ideas.

This completes setpoint programming and system testing.

Set the PROGRAM ENABLE dip switch to DISABLE to prevent accidental setpoint changes or tampering. By following this procedure, it should be fairly easy to install a similar control application. More details about each message is provided in *Chapter 5* and *Chapter 6*.

As you use the system, some setpoints may need adjusting. For example, frequent low temperature alarms might indicate that the setpoint value was set too close to normal heater temperature swings and needs to be lowered. Once the system has been operating normally for a while an alarm will indicate a change that needs investigation.

The flexibility and many features of the MS-2102 system significantly reduces problems caused by heat tracing malfunctions.

## Overview

The front panel provides the local operator with LCD alphanumeric display and keypad. The display and status indicators update alarm and status information automatically. The keypad is used to select the appropriate message for entering setpoints or displaying Measured Values.

The 32 character, backlit, LCD display provides English messages that are visible under various lighting conditions. When the display and keypad are not being used, the screen displays system information, which is definable through three user selected default messages. These default messages only appear after a user defined period of inactivity. Press either [SETPOINT], [MEASURED] or [STATUS] to override the default messages.

## Operating the Keypad

The MS-2102 display messages are organized into pages under headings **Setpoints** and **Measured Values**.

[SETPOINT]:	Provides entry to the Setpoint Menu which allows you to navigate through user settable parameters. See <i>Chapter 6 Setpoint Values</i> for detailed messages.
[MEASURED]:	Provides entry to the Measured Values Menu which you to navigate through measured parameters.
[STATUS]:	Provides immediate access to the System Status Menu which displays the alarm status for the Controller and allows access to individual alarm details.
[MESSAGE ↑]:	Allows you to move up through the selected menu.
[MESSAGE ↓]:	Allows you to move down through the selected menu.
[VALUE ↑]:	Allows you to increase the value of the displayed selected item.
[VALUE ↓]:	Allows you to decrease the value of the displayed selected item.
[STORE]:	Allows you to save the changed value of the selected item.
[RESET]:	Allows you to clear alarms that are no longer active.

## Status Lights

Refer to *Figure 4.1 Display, Front View*.

- **L10 Power:** The green **Power** light should be on at all times indicating that control power is applied to the Module. If the light is off, either there is no control power or the display has a malfunction and requires servicing.
- **L11 Heater:** The green **Heater** light is on if the heater is energized.
- **L12 Communicate:** Random flashing of the green **Communicate** light indicates that serial communications are active on the controller..
- **L13 System Fail:** The red **System** Fail light should be off, indicating that the system check was successful.
- **L14 Alarm:** The red **Alarm** light is off when there are no alarms. The light flashes if any alarm conditions are present. Press [STATUS] to view alarms.

## Alphanumeric Display

Refer to *Figure 4.1 Display, Front View*.

- **D10 Display:** Two lines with 16 alphanumeric characters per line. It is backlit for viewing in low-light conditions.

## Keypad

Refer to *Figure 4.1 Display, Front View*.

- **K10 Display Keypad:** Consists of nine keys which, when used in connection with the Alphanumeric Display, allow complete control of programming and monitoring of the Control Module.

## Display Contrast

Refer to *Figure 4.2 Contrast Control*.

- **P1 LCD display:** After the MS-2102 is field mounted, it may be necessary to adjust the display contrast to compensate for the viewing angle. To adjust the contrast, open the enclosure door and locate the potentiometer (labelled **DISPLAY CONTRAST** pot) on the board attached to the enclosure door. Turn the set-screw clockwise or counter-clockwise until the display is desirable.

## Heater Numbering

Each heater is identified by a number of the form “M-N”, where “M” is the Module Number and N is the heater circuit number within the control module. Each Control Module on the same data highway must have a unique Module Number.

Figure 4.1 Display, Front View

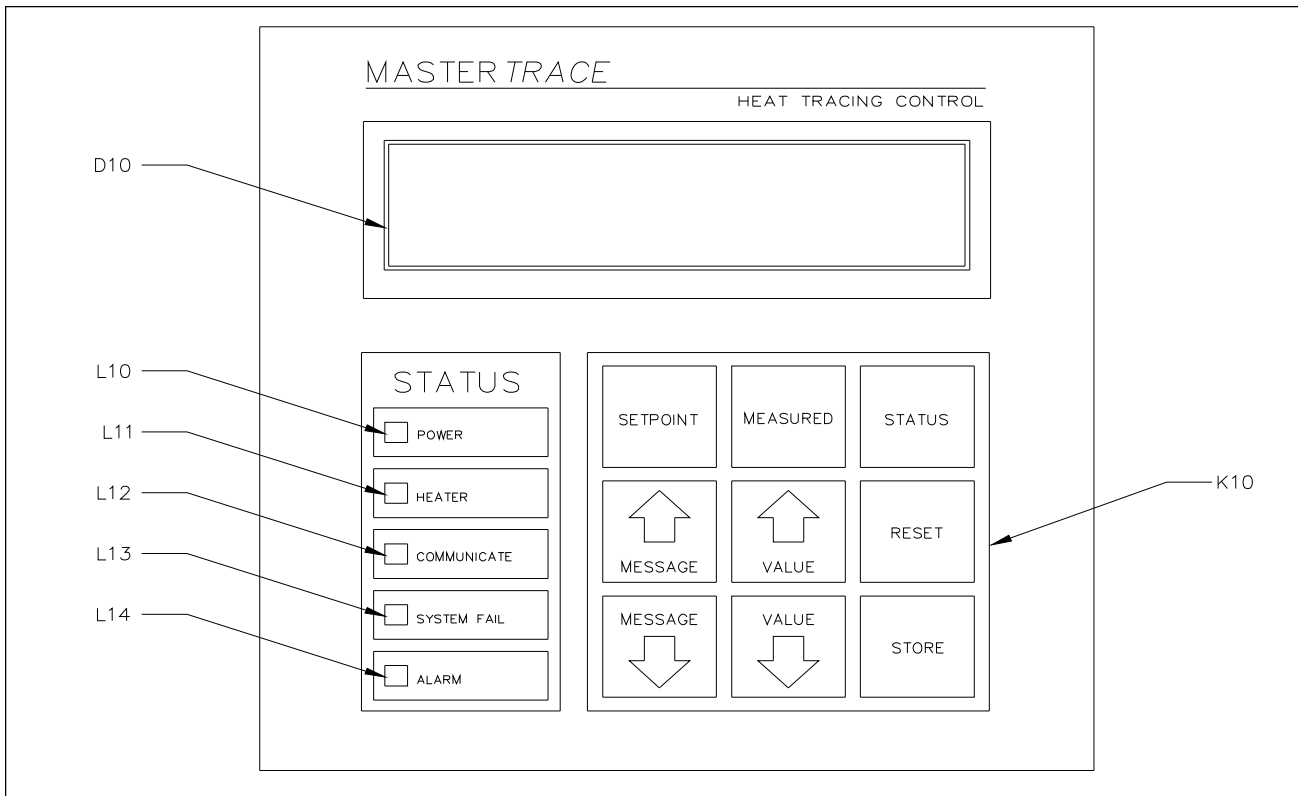
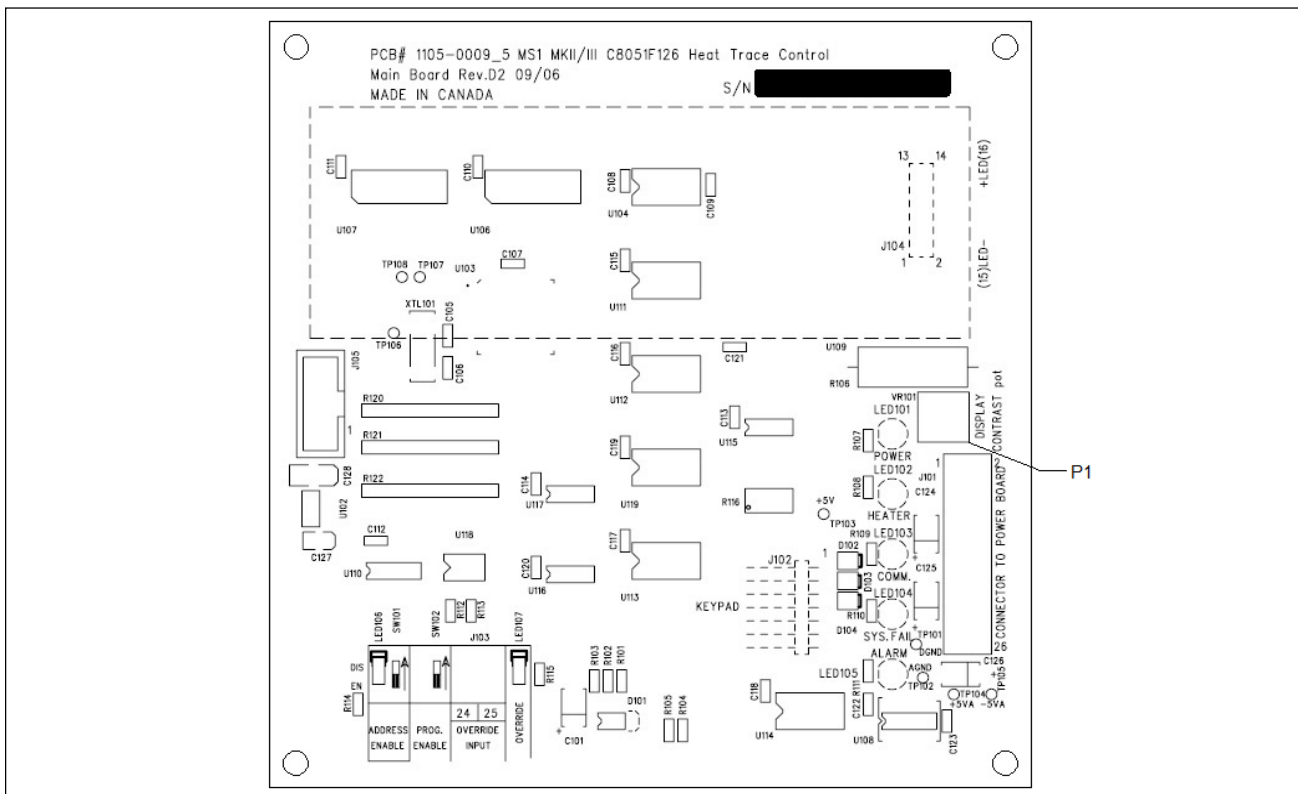

Figure 4.2 Contrast Control



### Startup Messages

Startup messages are displayed when power is applied to the controller.

MASTERTRACEHEAT  
TRACINGCONTROL

This message displays the controller model.

NEXTRON  
CORPORATION

This message displays company name of the supplier.

FIRMWARE VERSION  
D2-00-00

This messages displays the firmware version number.

SELF CHECK PASSED

This message appears when the controller has successfully completed execution of self-diagnostic functions.

SELF CHECK FAILED

This message appears when the controller has detected faults during self-diagnostic function execution or normal operation. This may be as result of memory or CPU failure. The controller requires servicing.

### Status Messages

Status messages are automatically displayed for any active conditions in the controller such as trips and alarms. These messages provide an indication of the current state of the controller.

Some messages prompt you to press [MESSAGE ↵] to scroll through messages to provide additional details of the controller status.

SYSTEM OK  
NO ALARMS

This message indicates there are no alarms present.

\*\*2 ALARMS\*\*  
PRESS MESSAGE DOWN

This message indicates the number of alarms on the controller. Press [MESSAGE ↵] to locate the problem and the cause.

PRESS MESSAGE DOWN  
FOR NEXT ALARM

This message marks the end of details to an alarm. Pressing [MESSAGE ↵] to scroll through details of the next alarm.

NO MORE ALARMS

This message appears when the user has scrolled through all alarms.

**Flash Messages**

Flash messages are warnings, errors or general information displayed in response to a key press. The duration of the message can be configured in SETPOINTS\SYSTEM

SETUP\SCAN TIME. The factory default is three seconds.

SETPOINT STORED

This message appears when a setpoint has been stored.

PRESET DISABLED  
ALARM ACTIVE

This message indicates that the alarm cannot be reset because the alarm condition is still present.

NAME STORED

This message appears when the heater name has been stored.

NOT STORED  
PROG DISABLED

This message indicates that the program enable dip switch or program access function is set to disable and programming is not allowed. Refer to *Chapter 6, Section 6.3*, for details on Setpoint Access Security.

Overview

Access values and statistics in the Measured Values mode. The messages are organized into groups for easy reference as shown below. Throughout this chapter each group is detailed by section.

[MEASURED] provides access to the Measured Values Menu which allows the user to display the Measured

Values of the selected heater in the control module.

The Measured Values Menu is arranged in two groups.

Pressing [MEASURED] twice quickly access the top of the second group. [MESSAGE ↑] allows you to move up through the selected menu. [MESSAGE ↓] allows you to move down through the selected menu.

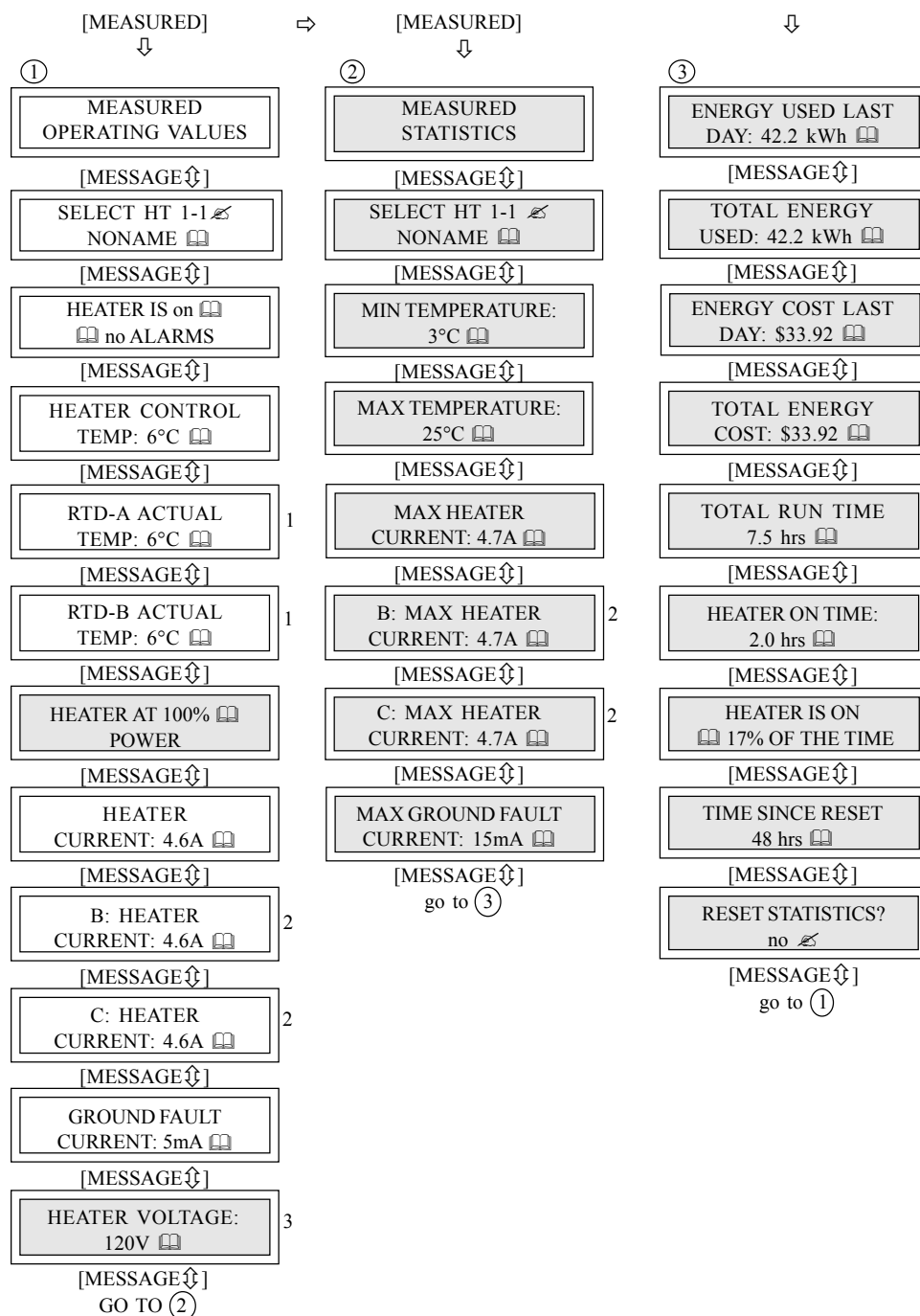

Restrictions

- 1. Dual RTD per circuit mode
- 2. 3-phase heater in MS2102-1TXHx panel
- 3. HTR SET VOLTAGE is set to *measured*.

Advanced User Mode



HEATER AT 100%   
POWER

MESSAGE NO: M1-07 APPLIES TO: Selected Heater  
DEFAULT VALUE: N/A VALUE RANGE: 0 to 100%  
DISPLAY MODE: Advanced RESTRICTIONS: None

The displayed value is the percentage duty cycle of the heater circuit. For example, with PROPORTIONAL CONTROL and/or POWER LIMIT on, a percentage duty cycle of 30% means that the circuit is energized for 3 out of 10 power cycles. For on/off switching, heater **on** is 100% and **off** is 0%.

HEATER  
CURRENT: 4.6A 

MESSAGE NO: M1-08 APPLIES TO: Selected Heater  
DEFAULT VALUE: N/A VALUE RANGE: 0 to 30.0/100.0 A, O.L.  
DISPLAY MODE: All RESTRICTIONS: None

The displayed value is the actual current/phase-A current of the heater circuit. If the heater is off, this value is zero. If the current exceeds the value range, then **O.L.** is displayed. The use of PROPORTIONAL CONTROL or POWER LIMIT functions can reduce the current from its nominal rating.

B: HEATER  
CURRENT: 4.6A 

MESSAGE NO: M1-09 APPLIES TO: Selected Heater  
DEFAULT VALUE: N/A VALUE RANGE: 0 to 100.0 A, O.L.  
DISPLAY MODE: All RESTRICTIONS: MS2102-1TXHx panel

The displayed value is the actual phase-B current of the heater circuit. If the heater is off, this value is zero. If the current exceeds the value range, then **O.L.** is displayed. The use of PROPORTIONAL CONTROL or POWER LIMIT functions can reduce the current from its nominal rating.

C: HEATER  
CURRENT: 4.6A 

MESSAGE NO: M1-10 APPLIES TO: Selected Heater  
DEFAULT VALUE: N/A VALUE RANGE: 0 to 100.0 A, O.L.  
DISPLAY MODE: All RESTRICTIONS: MS2102-1TXHx panel

The displayed value is the actual phase-C current of the heater circuit. If the heater is off, this value is zero. If the current exceeds the value range, then **O.L.** is displayed. The use of PROPORTIONAL CONTROL or POWER LIMIT functions can reduce the current from its nominal rating.

GROUND FAULT  
CURRENT: 15mA 

MESSAGE NO: M1-11 APPLIES TO: Selected Heater  
DEFAULT VALUE: N/A VALUE RANGE: 0, 10 to 1000 mA, O.L.  
DISPLAY MODE: All RESTRICTIONS: None

The displayed value is the ground leakage or ground fault current. If the current exceeds the value range, then **O.L.** is displayed.

HEATER VOLTAGE  
120V 

MESSAGE NO: M1-12 APPLIES TO: Selected Heater  
DEFAULT VALUE: N/A VALUE RANGE: 85 to 300 V, O.L.  
DISPLAY MODE: All RESTRICTIONS: HTR SET VOLTAGE is set to *measured*.

The displayed value is the measured supply voltage across terminal 2 & 3 on the Control Module. If the voltage exceeds the value range, then **O.L.** is displayed. For MS2102 controller, this voltage is always the voltage of the first heater circuit even when Selected Heater is selected to heater 2. For MS2102 panels, this voltage may be the voltage of the first heater circuit if heater 1's power-in voltage is also feeding to terminal 2 & 3 on the Control Module. This voltage is displayed and used as the heater voltage in statistics calculation for the selected heater when HTR SET VOLTAGE is set to *measured*.

Statistics

MEASURED:  
STATISTICS 

MESSAGE NO: M2-13 APPLIES TO: Control Module  
 DEFAULT VALUE: N/A VALUERANGE: N/A  
 DISPLAY MODE: Advanced RESTRICTIONS: None

SELECT HT M-1   
NONAME 

MESSAGE NO: M2-14 APPLIES TO: Control Module  
 DEFAULT VALUE: HT M-1 VALUE RANGE: HT M-1 to M-2  
 DISPLAY MODE: All RESTRICTIONS: None

This function selects the heater circuit. Each heater circuit has a unique Heater Number in a form of M-N. M is the Module Number of the Control Module and N is the heater circuit within the Control Module. Press [VALUE ↑] or [VALUE ↓] and then press [STORE] to select a heater circuit. For convenience and to reduce human error, the Heater Name is also displayed.

MIN TEMPERATURE:  
3°C 

MESSAGE NO: M2-15 APPLIES TO: Selected Heater  
 DEFAULT VALUE: N/A VALUERANGE: -50 to 500 °C  
 -58 to 932 °F, RTD Short

DISPLAY MODE: Advanced RESTRICTIONS: Heater Setpoint is not **off**.  
 The displayed value is the lowest Measured Temperature since the last reset. If the displayed value is **RTD Short**, a value less than the minimum range was recorded. To reset the displayed value press [RESET]. To reset with all statistics, use RESET STATISTICS.

MAX TEMPERATURE:  
25°C 

MESSAGE NO: M2-16 APPLIES TO: Selected Heater  
 DEFAULT VALUE: N/A VALUERANGE: -50 to 500 °C  
 -58 to 932 °F, RTD Open

DISPLAY MODE: Advanced RESTRICTIONS: Heater Setpoint is not **off**.  
 The displayed value is the highest Measured Temperature since the last reset. If the displayed value is **RTD OPEN**, a value greater than the maximum range was recorded. To reset the displayed value, press [RESET]. To reset with all statistics, use RESET STATISTICS.

MAX HEATER  
CURRENT: 4.7A 

MESSAGE NO: M2-17 APPLIES TO: Selected Heater  
 DEFAULT VALUE: N/A VALUERANGE: 0.1 to 30.0/100.0 A, O.L.  
 DISPLAY MODE: Advanced RESTRICTIONS: None

The displayed value is the highest heater/phase-A current since the last reset. If the displayed value is **O.L.**, a value greater than the maximum range was recorded. To reset the displayed value, press [RESET]. To reset with all statistics, use RESET STATISTICS.

B: MAX HEATER  
CURRENT: 4.7A 

MESSAGE NO: M2-18 APPLIES TO: Selected Heater  
 DEFAULT VALUE: N/A VALUERANGE: 0.1 to 100.0 A, O.L.  
 DISPLAY MODE: Advanced RESTRICTIONS: None

The displayed value is the highest heater phase-B current since the last reset. If the displayed value is **O.L.**, a value greater than the maximum range was recorded. To reset the displayed value, press [RESET]. To reset with all statistics, use RESET STATISTICS.

C: MAX HEATER  
CURRENT: 4.7A 

MESSAGE NO: M2-19 APPLIES TO: Selected Heater  
 DEFAULT VALUE: N/A VALUERANGE: 0.1 to 100.0 A, O.L.  
 DISPLAY MODE: Advanced RESTRICTIONS: None

The displayed value is the highest heater phase-C current since the last reset. If the displayed value is **O.L.**, a value greater than the maximum range was recorded. To reset the displayed value, press [RESET]. To reset with all statistics, use RESET STATISTICS.

MAX GROUND FAULT  
CURRENT: 15mA 

MESSAGE NO: M2-20 APPLIES TO: Selected Heater  
DEFAULT VALUE: N/A VALUE RANGE: 0, 10 to 1000 mA,O.L.  
DISPLAY MODE: Advanced RESTRICTIONS: None

The displayed value is the highest Ground Fault Current since the last reset. If the displayed value is **O.L.**, a value greater than the maximum range was recorded. To reset the displayed value, press [RESET]. To reset with all statistics, use RESET STATISTICS.

ENERGY USED LAST  
DAY: 42.2kWh 

MESSAGE NO: M2-21 APPLIES TO: Selected Heater  
DEFAULT VALUE: N/A VALUE RANGE: 0 to 1000 MWh  
DISPLAY MODE: Advanced RESTRICTIONS: None

The displayed value is the energy used in the day. Energy is calculated from the Heater Current times the Heater Voltage/HTR SET VOLTAGE integrated over time. This value is automatically updated once every 24 hours. It cannot be reset.

TOTAL ENERGY  
USED: 42.2kWh 

MESSAGE NO: M2-22 APPLIES TO: Selected Heater  
DEFAULT VALUE: N/A VALUE RANGE: 0 to 1000 MWh  
DISPLAY MODE: Advanced RESTRICTIONS: None

The displayed value is the energy used since the last reset. Energy is calculated from the Heater Current times the Heater Voltage/HTR SET VOLTAGE integrated over time. If the displayed value is **O.L.**, a value greater than the maximum range was recorded. To reset, use RESET STATISTICS.

ENERGY COST LAST  
DAY: \$33.92 

MESSAGE NO: M2-23 APPLIES TO: Selected Heater  
DEFAULT VALUE: N/A VALUE RANGE: \$0 to \$100,000.00  
DISPLAY MODE: Advanced RESTRICTIONS: None

The displayed value is the energy cost in the last day. Energy cost is calculated from the Energy Used times the COST PER kWh. This value is automatically updated once every 24 hours. It cannot be reset.

TOTAL ENERGY  
COST: \$33.92 

MESSAGE NO: M2-24 APPLIES TO: Selected Heater  
DEFAULT VALUE: N/A VALUE RANGE: \$0 to \$100,000.00  
DISPLAY MODE: Advanced RESTRICTIONS: None

The displayed value is the energy cost since the last reset. Energy cost is calculated from the Energy Used times the COST PER kWh. To reset, use RESET STATISTICS.

TOTAL RUN TIME  
20966 hrs 

MESSAGE NO: M2-25 APPLIES TO: Control Module  
DEFAULT VALUE: N/A VALUE RANGE: 0 to 999,999 hours  
DISPLAY MODE: Advanced RESTRICTIONS: None

The displayed value is the total time since power was first applied to the Control Module. It is useful for maintenance purpose. It cannot be reset.

HEATER ON TIME  
80 hrs 

MESSAGE NO: M2-26 APPLIES TO: Selected Heater  
DEFAULT VALUE: N/A VALUE RANGE: 0 to 999,999 hours  
DISPLAY MODE: Advanced RESTRICTIONS: None

The displayed value is the accumulated time that the heater circuit has been on since the last reset. It indicates how active the heater circuit is and can be useful for maintenance. To reset use, RESET STATISTICS.

HEATER IS ON  
17% OF THE TIME

MESSAGE NO: M2-27 APPLIES TO: Selected Heater  
DEFAULT VALUE: N/A VALUE RANGE: 0 to 100%  
DISPLAY MODE: Advanced RESTRICTIONS: None

The displayed value is the percentage of time that the heater circuit has been on since the last reset.  $PERCENT\ ON\ TIME = HEATER\ ON\ TIME \div TIME\ SINCE\ RESET \times 100\%$ . It indicates how active the heater circuit is and can be useful for maintenance. Interpretation of this value depends on the process but large changes could be an indication of degradation of the heater or the insulation. To reset, use RESET STATISTICS.

TIME SINCE RESET  
48 hrs

MESSAGE NO: M2-28 APPLIES TO: Control Module  
DEFAULT VALUE: N/A VALUE RANGE: 0 to 999,999 hours  
DISPLAY MODE: Advanced RESTRICTIONS: None

The displayed value is the total time since the last reset. It can only be reset by factory reset or module reset commission.

RESET STATISTICS?  
no

MESSAGE NO: M2-29 APPLIES TO: Selected Heater  
DEFAULT VALUE: N/A VALUE RANGE: yes, no  
DISPLAY MODE: Advanced RESTRICTIONS: None

This function resets all the statistical values except Total Run Time/Time Since Reset, Energy Used Last Day/Total Energy Used, Energy Cost Last Day/Total Energy Cost **for the selected heater**. Select **yes** and then press [STORE]. You are asked to confirm your request. Again, select **yes** and then press [STORE]. The statistical values are now cleared.

ARE YOU SURE?  
no

Overview

The MS-2102 has a considerable number of programming setpoints for flexibility. Setpoint messages are organized into groups for easy reference as shown below. Throughout this chapter each group is detailed by section.

[SETPOINT] provides entry to the Setpoint Menu which

allows you to program and test the Control Module. The Setpoint Menu is arranged in four groups. Pressing [SETPOINT] twice quickly to access the top of the second group; press three times to access the top of the third group, and so on.

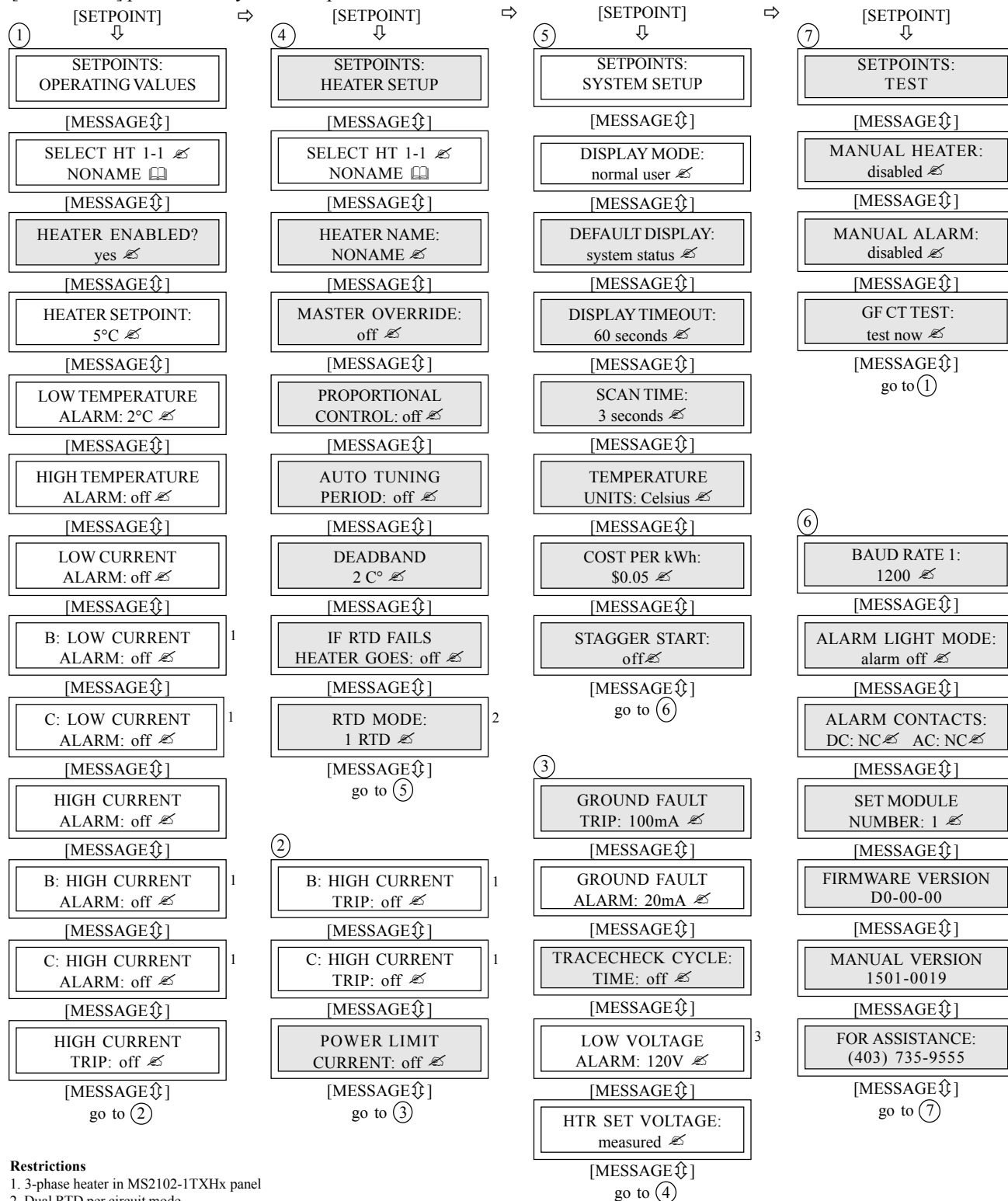

Restrictions

- 1. 3-phase heater in MS2102-1TXHx panel
- 2. Dual RTD per circuit mode
- 3. HTR SET VOLTAGE is set to *measured*.

Advanced User Mode

**Setpoints Entering**

Prior to operating the heat trace, you must enter process setpoints, alarm levels and alarm output configuration via front panel keypad and display, RS485 port or SCADA system running user written software.

The MS-2102 leaves the factory with default setpoint values shown in the message details. You can leave many of the factory default settings unchanged.



**Warning: As a minimum, enter setpoints in the operating values group (S1) to ensure proper operation of the heat trace.**

**Setpoint Access Security**

The setpoint access security is achieved via the Program Enable Dip Switch. You can program setpoints through the keypad by setting the program enable dip switch to the **ENABLE** position. Access the dip switch by opening the enclosure door and locating the switch at the bottom of the board on the enclosure door. When setpoint programming is complete, return the dip switch to the disable position. Disabling Program Enable does not restrict setpoint access through the communications.

**Operating**



MESSAGE NO: S1-01  
 DEFAULT VALUE: N/A  
 DISPLAY MODE: All

APPLIES TO: Control Module  
 VALUE RANGE: N/A  
 RESTRICTIONS: None

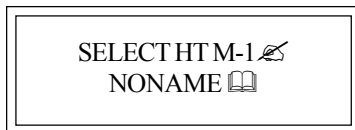

MESSAGE NO: S1-02  
 DEFAULT VALUE: HT M-1  
 DISPLAY MODE: All

APPLIES TO: Control Module  
 VALUE RANGE: HT M-1 to M-2  
 RESTRICTIONS: None

This function selects the heater circuit. Each heater circuit has a unique Heater Number in a form of M-N. M is the Module Number of the Control Module and N is the heater circuit within the Control Module. Press [VALUE ↑] or [VALUE ↓] and then press [STORE] to select a heater circuit. For convenience and to reduce human error, the Heater Name is also displayed.

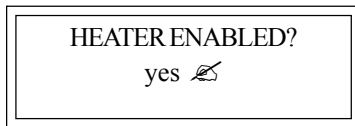

MESSAGE NO: S1-03  
 DEFAULT VALUE: yes  
 DISPLAY MODE: Advanced

APPLIES TO: Selected Heater  
 VALUE RANGE: yes, no  
 RESTRICTIONS: None

This function enables control and monitoring for the heater circuit. You cannot access setpoints and measured value messages unless the heater is enabled. Select **no** if the circuit is not used.

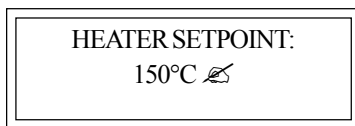

MESSAGE NO: S1-04  
 DEFAULT VALUE: 20 °C  
 68 °F  
 DISPLAY MODE: All

APPLIES TO: Selected Heater  
 VALUE RANGE: -50 to 500 °C, none, off  
 -58 to 932 °F, none, off  
 RESTRICTIONS: None

This function sets the maintain temperature. For on-off control, the circuit is energised if the Heater Control Temperature is less than the Heater Setpoint less the deadband. The circuit is de-energised if the Heater Control Temperature is greater than the Heater Setpoint plus the deadband. Both the PROPORTIONAL CONTROL and the POWER LIMIT functions affect heater switching. If the Heater Setpoint is set to **none**, then the heater circuit is on and has temperature monitoring with no temperature control. If the Heater Setpoint is set to **off** then the heater circuit is on and has no temperature monitoring or control.



C: LOW CURRENT  
ALARM: 10.5A 

MESSAGE NO: S1-09      APPLIES TO: Selected Heater  
DEFAULT VALUE: off      VALUE RANGE: 0.5 to 30.0/100.0 A, off  
DISPLAY MODE: All      RESTRICTIONS: MS2102-1TXHx panel

This function sets the phase C: Low Current Alarm setpoint. *It must be less than the phase C: High Current Alarm setpoint.* To disable this alarm, set the value to **off**. When the phase C: Heater Current is less than or equal to this setpoint, the phase C: Low Current Alarm is activated and a **C: LOW CURRENT ALARM** message is added to the System Status messages. The alarm deactivates when the phase C: Heater Current rises above this alarm setpoint. The value range is in 0.5 A increments.

*Note: This setpoint is based on the heater at 100% power. If Proportional Control or Power Limit is enabled, all current measurements will be converted to 100% power; based on a constant resistive load, before being compared to the alarm setpoint.*

HIGH CURRENT  
ALARM: 15.0A 

MESSAGE NO: S1-10      APPLIES TO: Selected Heater  
DEFAULT VALUE: off      VALUE RANGE: 0.5 to 30.0/100.0 A, off  
DISPLAY MODE: All      RESTRICTIONS: None

This function sets the High Current Alarm setpoint. *It must be greater than the Low Current Alarm setpoint.* To disable this alarm, set the value to **off**. When the Heater Current is greater than or equal to this setpoint, the High Current Alarm is activated and a **HIGH CURRENT ALARM** message is added to the System Status messages. The alarm deactivates when the Heater Current falls below this alarm setpoint. The value range is in 0.5 A increments.

*Note: High current alarm is disabled when proportional control, or power limit functions are operating the heater below 100% duty cycle to prevent erroneous alarms at low duty cycles.*

B: HIGH CURRENT  
ALARM: 15.0A 

MESSAGE NO: S1-11      APPLIES TO: Selected Heater  
DEFAULT VALUE: off      VALUE RANGE: 0.5 to 30.0/100.0 A, off  
DISPLAY MODE: All      RESTRICTIONS: MS2102-1TXHx panel

This function sets the phase B: High Current Alarm setpoint. *It must be greater than the phase B: Low Current Alarm setpoint.* To disable this alarm, set the value to **off**. When the phase B: Heater Current is greater than or equal to this setpoint, the phase B: High Current Alarm is activated and a **B: HIGH CURRENT ALARM** message is added to the System Status messages. The alarm deactivates when the phase B: Heater Current falls below this alarm setpoint. The value range is in 0.5 A increments.

*Note: High current alarm is disabled when proportional control, or power limit functions are operating the heater below 100% duty cycle to prevent erroneous alarms at low duty cycles.*

C: HIGH CURRENT  
ALARM: 15.0A 

MESSAGE NO: S1-12      APPLIES TO: Selected Heater  
DEFAULT VALUE: off      VALUE RANGE: 0.5 to 30.0/100.0 A, off  
DISPLAY MODE: All      RESTRICTIONS: MS2102-1TXHx panel

This function sets the phase C: High Current Alarm setpoint. *It must be greater than the phase C: Low Current Alarm setpoint.* To disable this alarm, set the value to **off**. When the phase C: Heater Current is greater than or equal to this setpoint, the phase C: High Current Alarm is activated and a **C: HIGH CURRENT ALARM** message is added to the System Status messages. The alarm deactivates when the phase C: Heater Current falls below this alarm setpoint. The value range is in 0.5 A increments.

*Note: High current alarm is disabled when proportional control, or power limit functions are operating the heater below 100% duty cycle to prevent erroneous alarms at low duty cycles.*

HIGH CURRENT  
TRIP: 15.0A 

MESSAGE NO: S1-13      APPLIES TO: Selected Heater  
DEFAULT VALUE: off      VALUE RANGE: 0.5 to 30.0/100.0 A, off  
DISPLAY MODE: All      RESTRICTIONS: None

This function sets the High Current Trip setpoint. *It must be greater than the Low Current Alarm setpoint and the High Current Alarm setpoint.* To disable this trip function, set the value to **off**. When the Heater Current is greater than or equal to this setpoint, the heater circuit is open, a High Current Trip Alarm is activated and a **HIGH CURRENT TRIP ALARM** message is added to the System Status messages. This is a latching alarm. When the cause of the alarm has been corrected, locate the alarm message in the Status Menu and press [RESET].

*Note: This setpoint is based on the heater at 100% power. If Proportional Control or Power Limit is enabled, all current measurements will be converted to 100% power, based on a constant resistive load, before being compared to the alarm setpoint.*

B: HIGH CURRENT  
TRIP: 15.0A 

MESSAGE NO: S1-14      APPLIES TO: Selected Heater  
DEFAULT VALUE: off      VALUE RANGE: 0.5 to 30.0/100.0 A, off  
DISPLAY MODE: All      RESTRICTIONS: None

This function sets the phase B: High Current Trip setpoint. *It must be greater than the phase B: Low Current Alarm setpoint and the phase B: High Current Alarm setpoint.* To disable this trip function, set the value to **off**. When the phase B: Heater Current is greater than or equal to this setpoint, the heater circuit is open, a B: High Current Trip Alarm is activated and a **B: HIGH CURRENT TRIP ALARM** message is added to the System Status messages. This is a latching alarm. When the cause of the alarm has been corrected, locate the alarm message in the Status Menu and press [RESET].

*Note: This setpoint is based on the heater at 100% power. If Proportional Control or Power Limit is enabled, all current measurements will be converted to 100% power, based on a constant resistive load, before being compared to the alarm setpoint.*

C: HIGH CURRENT  
TRIP: 15.0A 

MESSAGE NO: S1-15      APPLIES TO: Selected Heater  
DEFAULT VALUE: off      VALUE RANGE: 0.5 to 30.0/100.0 A, off  
DISPLAY MODE: All      RESTRICTIONS: None

This function sets the phase C: High Current Trip setpoint. *It must be greater than the phase C: Low Current Alarm setpoint and the phase C: High Current Alarm setpoint.* To disable this trip function, set the value to **off**. When the phase C: Heater Current is greater than or equal to this setpoint, the heater circuit is open, a C: High Current Trip Alarm is activated and a **C: HIGH CURRENT TRIP ALARM** message is added to the System Status messages. This is a latching alarm. When the cause of the alarm has been corrected, locate the alarm message in the Status Menu and press [RESET].

*Note: This setpoint is based on the heater at 100% power. If Proportional Control or Power Limit is enabled, all current measurements will be converted to 100% power, based on a constant resistive load, before being compared to the alarm setpoint.*

POWER LIMIT CURRENT:  
20.5A 

MESSAGE NO: S1-16      APPLIES TO: Selected Heater  
DEFAULT VALUE: off      VALUE RANGE: 0.5 to 30.0/100.0 A, off  
DISPLAY MODE: Advanced      RESTRICTIONS: None

This function sets the maximum average current that flows in the heater circuit. It is useful for limiting the inrush current of self-regulating cable or reducing the power output of constant wattage heaters. Set the value below the breaker rating or to the maximum power desired (Wattage=Heater Voltage x Power Limit value). The value range is in 0.5 A increments.

GROUND FAULT  
TRIP: 100mA 

MESSAGE NO: S1-17      APPLIES TO: Selected Heater  
DEFAULT VALUE: 30 mA      VALUERANGE: 10 to 1000 mA, off  
DISPLAY MODE: Advanced      RESTRICTIONS: None

This function sets the Ground Fault Trip setpoint. *It must be greater than the Ground Fault Alarm setpoint.* When the Ground Fault Current is greater than or equal to this setpoint, the heater circuit is opened, the Ground Fault Trip Alarm is activated, and a **GROUND FAULT TRIP** message is added to the System Status messages. This is a latching alarm. When the cause of the alarm has been corrected, locate the alarm message in the Status Menu and press [RESET]. The value range is in 1 mA increments.

GROUND FAULT  
ALARM: 20mA 

MESSAGE NO: S1-18      APPLIES TO: Selected Heater  
DEFAULT VALUE: 20 mA      VALUERANGE: 10 to 1000 mA, off  
DISPLAY MODE: All      RESTRICTIONS: None

This function sets the Ground Fault Alarm setpoint. *It must be less than the Ground Fault Trip setpoint.* To disable this alarm, set the value to **off**. When the Ground Fault Current is greater than or equal to this setpoint, the Ground Fault Alarm is activated, and a **GROUND FAULT ALARM** message is added to the System Status messages. The alarm deactivates when the Ground Fault Current falls below this alarm setpoint. The value range is in 1 mA increments.

TRACECHECK CYCLE  
TIME: 4 hours 

MESSAGE NO: S1-19      APPLIES TO: Selected Heater  
DEFAULT VALUE: off      VALUERANGE: 1 to 24 hours, off  
DISPLAY MODE: Advanced      RESTRICTIONS: None

This function sets the frequency at which TraceCheck is activated. TraceCheck is a feature that exercises the system by automatically applying power to the heater if off for about 30 seconds. If an alarm condition is detected during this period, the TraceCheck™ Alarm is activated, and a **ALARM DURING TRACECHECK** message is added to the System Status messages. If a ground fault is detected, the heater circuit is opened. This is a latching alarm. To clear the alarm, locate the alarm message in the Status Menu and press [RESET]. To disable this feature, set the value to **off**. TraceCheck™ decreases maintenance by providing an early warning of problems that would otherwise go undetected until the heater was needed.

LOW VOLTAGE  
ALARM: 100 V 

MESSAGE NO: S1-20      APPLIES TO: Selected Heater  
DEFAULT VALUE: off      VALUERANGE: 85 to 300 V, off  
DISPLAY MODE: All      RESTRICTIONS: HTR SET VOLTAGE is set to *measured*.

This function sets the Low Voltage Alarm setpoint. To disable this alarm, set the value to **off**. When the Heater Voltage is less than or equal to this setpoint, the Low Voltage Alarm is activated and a **LOW VOLTAGE ALARM** message is added to the System Status messages. The alarm deactivates when the Heater Voltage rises above this alarm setpoint.

HTR SET VOLTAGE:  
measured 

MESSAGE NO: S1-21      APPLIES TO: Selected Heater  
DEFAULT VALUE: measured      VALUERANGE: 100 to 600 V, measured  
DISPLAY MODE: All      RESTRICTIONS: None

This function sets the value (100~600V) of heater voltage in the statistics calculation of the selected heater. When it is set to *measured*, the measured supply voltage across terminal 2 & 3 on the Control Module is used in the calculation of heater statistics and low voltage alarm.

## Heater Setup

SETPOINTS: HEATER SETUP
----------------------------

MESSAGE NO: S2-01      APPLIES TO: Control Module  
 DEFAULT VALUE: N/A      VALUE RANGE: N/A  
 DISPLAY MODE: Advanced      RESTRICTIONS: None  
 This message displays the name of the sub-menu when entered.

SELECT HT M-1  NONAME 
---

MESSAGE NO: S2-02      APPLIES TO: Control Module  
 DEFAULT VALUE: HT M-1      VALUE RANGE: HT M-1 to M-2  
 DISPLAY MODE: Advanced      RESTRICTIONS: None  
 This function selects the heater circuit. Each heater circuit has a unique Heater Number in a form of M-N. M is the Module Number of the Control Module and N is the heater circuit within the Control Module. Press [VALUE ↑] or [VALUE ↓] and then press [STORE] to select a heater circuit. For convenience and to reduce human error, the Heater Name is also displayed.

HEATER NAME: NONAME 
--

MESSAGE NO: S2-03      APPLIES TO: Selected Heater  
 DEFAULT VALUE: NONAME      VALUE RANGE: 16 Alphanumeric Characters  
 DISPLAY MODE: Advanced      RESTRICTIONS: None  
 This function sets the Heater Name. It provides a unique, identifiable tag or label for the heater circuit. The Heater Name consists of 16 alphanumeric characters that you enter one at a time from left to right. The cursor indicates which character is being selected. Press [VALUE ↑] or [VALUE ↓] to change the character. Move to the next character by pressing [STORE]. Continue in this way until all 16 characters are entered. Press [STORE] in the last character position to save the Heater Name.

MASTER OVERRIDE: off 
---

MESSAGE NO: S2-04      APPLIES TO: Selected Heater  
 DEFAULT VALUE: off      VALUE RANGE: on, off  
 DISPLAY MODE: Advanced      RESTRICTIONS: None  
 This feature sets the response of the heater circuit to the Control Module's Master Override input. The Master Override input responds to a contact closure. If the Master Override is set to **off** or the Master Override inputs are shorted, control of the heater circuit operates normally based on the Heater Control Temperature and the Heater Setpoint. If the Master Override is set to **on** and the Master Override inputs are open, the heater circuit is opened regardless of the Heater Control Temperature. This feature allows selected circuits to be turned off for load shedding or for an ambient temperature override. If the Heater Setpoint is set to **off** or **none** and the Master Override is set to **on**, the Master Override inputs will have full control over the heater circuit.

PROPORTIONAL CONTROL: off 
--

MESSAGE NO: S2-05      APPLIES TO: Selected Heater  
 DEFAULT VALUE: off      VALUE RANGE: on, off  
 DISPLAY MODE: Advanced      RESTRICTIONS: Heater Setpoint must not be **off**.

This function minimizes temperature overshoot and undershoot for tighter temperature control. For critical temperature maintenance applications you can obtain more accurate control by using this feature. However, the time to reach Heater Setpoint may be longer. With Proportional Control set to **on**, as the Heater Control Temperature approaches the Heater Setpoint, the percent duty cycle of the heater is reduced. With Proportional Control set to **off**, on-off control is used.



System Setup

SETPOINTS:  
SYSTEM SETUP

MESSAGE NO: S3-01 APPLIES TO: Control Module  
 DEFAULT VALUE: N/A VALUERANGE: N/A  
 DISPLAY MODE: All RESTRICTIONS: None  
 This message displays the name of the sub-menu when entered.

DISPLAY MODE:  
advanced user 

MESSAGE NO: S3-02 APPLIES TO: Control Module  
 DEFAULT VALUE: advanced user VALUERANGE: advanced user, normal user  
 DISPLAY MODE: All RESTRICTIONS: None  
 This function determines what messages are displayed. If set to **advanced user**, all messages are displayed. If set to **normal user**, only the basic messages are displayed. Each message listed in this chapter shows the Display Mode required to see the message. **Advanced** indicates that you must set the display mode to **advanced user** to view the message.

DEFAULT DISPLAY:  
System Status 

MESSAGE NO: S3-03 APPLIES TO: Control Module  
 DEFAULT VALUE: System status VALUERANGE: See values below  
 DISPLAY MODE: Advanced RESTRICTIONS: Heater Temp messages are not displayed if Heater setpoint is **off**.

This function specifies the information that will be displayed when no key has been pressed for the Display Timeout interval as described below.

VALUE	INFORMATION DISPLAYED
System status	Alarm status
Heater status	Heater on or off
Heater temp	Control temperature

DISPLAY TIMEOUT:  
60 seconds 

MESSAGE NO: S3-04 APPLIES TO: Control Module  
 DEFAULT VALUE: 60 s VALUERANGE: 5 to 600 s, off  
 DISPLAY MODE: Advanced RESTRICTIONS: None  
 This function sets the length of time, from the last key press, to automatically return to the Default Display information. To disable this function, set the value to **off**.

SCAN TIME:  
2 seconds 

MESSAGE NO: S3-05 APPLIES TO: Control Module  
 DEFAULT VALUE: 3 s VALUERANGE: 1 to 10 s  
 DISPLAY MODE: Advanced RESTRICTIONS: None  
 This function sets the length of time between the display of successive messages. Select a value that is comfortable for the viewing speed of the operator.

TEMPERATURE UNITS:  
Celcius 

MESSAGE NO: S3-06 APPLIES TO: Control Module  
 DEFAULT VALUE: Celsius VALUERANGE: Celsius, Fahrenheit  
 DISPLAY MODE: Advanced RESTRICTIONS: Heater Setpoint must not be **off**.

This function sets the units of measure for temperature. All temperatures are displayed in the selected units of either degrees Celsius (°C) or degrees Fahrenheit (°F).

COST PER kWh:  
\$0.05 

MESSAGE NO: S3-07 APPLIES TO: Control Module  
 DEFAULT VALUE: \$0.05 VALUERANGE: \$0.01 to \$0.50  
 DISPLAY MODE: Advanced RESTRICTIONS: None  
 This function sets the COST PER kWh. The controller uses this value to calculate Energy Cost.

STAGGER START:  
off 

MESSAGE NO: S3-08 APPLIES TO: Control Module  
 DEFAULT VALUE: off VALUE RANGE: on, off  
 DISPLAY MODE: Advanced RESTRICTIONS: None

This function staggers the power up of heater circuits to eliminate tripping of the main breaker. If this value is set to “on”, the second heater will be turned on one minute after the power up if the circuit is calling for heat.

BAUD RATE:  
1200 

MESSAGE NO: S3-09 APPLIES TO: Control Module  
 DEFAULT VALUE: 1200 VALUE RANGE: 600,1200,2400,4800,9600  
 DISPLAY MODE: Advanced RESTRICTIONS: None

This function sets the communication baud rate for the RS-485 serial port. All controllers connected to the same data highway must operate at the same baud rate.

ALARM LIGHT MODE:  
alarm: off 

MESSAGE NO: S3-10 APPLIES TO: Control Module  
 DEFAULT VALUE: alarm:off VALUE RANGE: alarm:off, alarm:on  
 flash/on, flash/off  
 DISPLAY MODE: Advanced RESTRICTIONS: None

This function determines the response of the alarm light output to an alarm. The alarm light output is designed to drive a 5Vdc LED. If the value is set to **alarm off**, the alarm light is **on** in a no alarm condition and turns **off** when alarms are present. The **alarm off** setting works best with a green LED for fail-safe mode where loss of power or a burnt out LED generates an alarm condition. Value **alarm on**, turns the alarm light **off** in a no alarm condition and turns **on** when alarms are present. Value **alarm flash/on** flashes the alarm light when alarms are present and turns **on** the alarm light when there are no alarms. Value **alarm flash/off** flashes the alarm light when alarms are present and turns **off** the alarm light when there are no alarms.

ALARM CONTACTS:  
MECH:NO  SS:N/A 

MESSAGE NO: S3-11 APPLIES TO: Control Module  
 DEFAULT VALUE: MECH:NC VALUE RANGE: MECH:NO SS:N/A  
 SS:N/A MECH:NO SS:N/A  
 MECH:NC SS:N/A  
 MECH:NC SS:N/A,

DISPLAY MODE: Advanced RESTRICTIONS: None  
 This function configures the alarm contacts for normally open (NO) or normally closed (NC). MECH refers to the mechanical alarm contact on terminals 20 and 21 of the Control Module. SS refers to the solid state alarm contact that is not available on board. In **NO** mode, the contact closes during alarm condition. In **NC** mode, the contact opens during alarm condition.

SET MODULE  
NUMBER: 1 

MESSAGE NO: S3-12 APPLIES TO: Control Module  
 DEFAULT VALUE: 1 VALUE RANGE: 1-250  
 DISPLAY MODE: Advanced RESTRICTIONS: None

This function changes the Module Number of the Control Module. If a controller is to communicate along with other modules to a central computer or display, each module must have a unique address to ensure only one module attempts to communicate with the remote display at any time. The address for communication is the module number.

FIRMWARE VERSION  
D0-00-00

MESSAGE NO: S3-13 APPLIES TO: Control Module  
 DEFAULT VALUE: N/A VALUE RANGE: N/A  
 DISPLAY MODE: Advanced RESTRICTIONS: None

This message displays the firmware version number.

MANUAL VERSION  
1501-0019

MESSAGE NO: S3-14 APPLIES TO: Control Module  
 DEFAULT VALUE: N/A VALUE RANGE: N/A  
 DISPLAY MODE: Advanced RESTRICTIONS: None  
 This message displays the operator manual version or recorder number.

FOR ASSISTANCE:  
(403) 735-9555

MESSAGE NO: S3-15 APPLIES TO: Control Module  
 DEFAULT VALUE: N/A VALUE RANGE: N/A  
 DISPLAY MODE: Advanced RESTRICTIONS: None  
 This message displays the factory telephone number.

### Setpoint Tests

SETPOINTS  
TEST

MESSAGE NO: S4-01 APPLIES TO: Control Module  
 DEFAULT VALUE: N/A VALUE RANGE: N/A  
 DISPLAY MODE: Advanced RESTRICTIONS: None  
 This message displays the name of the sub-menu when entered.

MANUAL HEATER:  
disabled 

MESSAGE NO: S4-02 APPLIES TO: Selected Heater  
 DEFAULT VALUE: disabled VALUE RANGE: 1 to 24 hrs, disabled,  
 on continuously  
 DISPLAY MODE: Advanced RESTRICTIONS: None  
 This function manually overrides heater control for maintenance purposes. For normal operation, set to **disable**. If you select a period of time, the heater is forced **on** for the selected interval. If you select **on continuously**, the heater is forced on until you select **disabled**.

MANUAL ALARM:  
disabled 

MESSAGE NO: S4-03 APPLIES TO: Selected Control Module  
 DEFAULT VALUE: disabled VALUE RANGE: 1 to 24 hrs, disabled,  
 on continuously  
 DISPLAY MODE: Advanced RESTRICTIONS: None  
 This function manually controls the alarm output for maintenance purposes. For normal operation, set to **disable**. If you select a period of time, the alarm output is forced into alarm state for the selected interval. If you select **on continuously**, the alarm output is forced into alarm state until you select **disabled**. Alarm state is determined by ALARM CONTACTS function setting.

GF CT TEST  
test now 

MESSAGE NO: S4-04 APPLIES TO: Control Module  
 DEFAULT VALUE: disabled VALUE RANGE: 1 to 24 hrs, test now,  
 disabled  
 DISPLAY MODE: Advanced RESTRICTIONS: None  
 This function tests the ground fault monitoring function of the Control Module to ensure proper operation. When the ground fault CT test is turned **on**, the Control Module applies an ac current to the ground fault transformer and checks the measured ground fault currents. If the Control Module does not see the test current for a heater, the GF CT Test Alarm is activated, and a **GF CT** message is added to the system status messages. This is a latching alarm. When the cause of the alarm has been corrected, locate the alarm message in the Status Menu and press [RESET]. If there is no problem detected, no alarm message is displayed.

## Overview

The MS-2102 is capable of generating many different types of alarms. In this chapter, alarms are organized in three groups: trip or failure, heater and warning. Each group represents a level of severity with the trip or failure type being extremely critical, the process type requiring some attention and warning type indicating those that do not require immediate attention. Each group is detailed by

section throughout this chapter.

Access alarms by pressing [STATUS] where the total number of alarms is displayed. You must review each alarm by pressing [MESSAGE ↓] several times, each time displaying information about each alarm including the alarm name and reason for the alarm.

## Trip or Failure Alarms

### GROUND FAULT ALARM

The measured ground fault current is greater than or equal to the Ground Fault Alarm setpoint or, the ground fault current is greater than the maximum value range.

- ✓ Check that the setpoint is appropriate for the length and type of cable.
- ✓ Check for wet or damaged heating cable, power connections, splices, or tees.
- ✓ Test for correct ground fault measurement.

### GROUND FAULT TRIP

The measured ground fault current is greater than or equal to the Ground Fault Trip setpoint.

- ✓ Check that the setpoint is appropriate for the length and type of cable.
- ✓ Check for wet or damaged heating cable, power connections, splices, or tees.
- ✓ Test for correct ground fault measurement.

### SELF TEST FAILURE ALARM

A memory or CPU failure has occurred.

- ✓ The Control Module needs repair.

### GF CT TEST FAIL

Ground fault monitoring function did not detect the GF CT test current.

- ✓ Ground fault current transformer may be faulty.
- ✓ Ground fault monitoring function may be faulty, and controller needs repair.

### RELAY FAILURE ALARM

The heater current is greater than or equal to 0.1 A when the heater circuit is off.

- ✓ Check SCRs for failure in short circuit state.
- ✓ The controller may be faulty and needs repair.

### RTD FAILURE ALARM

The temperature derived from the RTD resistance has exceeded 500 °C or dropped below -50°C

- ✓ Check for damaged RTD, cable or open/short connection.
- ✓ Check the middle lead of RTD (terminal 7 or 11) for open connection.
- ✓ Pipe temperature has exceeded 500°C.
- ✓ Pipe temperature has dropped below -50°C.
- ✓ Test the RTD input.

**Process Alarms**

HIGHTEMPERATURE ALARM
--------------------------

The Heater Control Temperature is greater than or equal to the High Temperature Alarm setpoint.

- ✓ Check that the alarm setpoint is correct.
- ✓ Test for correct RTD operation.
- ✓ Check the heat trace design.

LOWTEMPERATURE ALARM
-------------------------

The Heater Control Temperature is less than or equal to the Low Temperature Alarm setpoint.

- ✓ Check that the alarm setpoint is correct.
- ✓ Test for correct RTD operation.
- ✓ Check for damaged insulation or cladding.
- ✓ Check for damaged heat trace.
- ✓ Check the heat trace design.

HIGHCURRENT ALARM
----------------------

The measured Heater Current, when the heater circuit is **on**, is greater than or equal to the High Current Alarm setpoint or, the Heater Current is greater than the maximum value range.

- ✓ Check that the alarm setpoint is correct.
- ✓ For self-regulating heating cable, the current varies substantially with temperature. Check that the alarm setpoint accounts for this variation or use the heat trace curve function.
- ✓ Test for correct current measurement.

LOWCURRENT ALARM
---------------------

The measured Heater Current, when the heater circuit is **on**, is less than or equal to the Low Current Alarm setpoint.

- ✓ Check that the alarm setpoint is correct.
- ✓ For self-regulating heating cable, the current varies substantially with temperature. Check that the alarm setpoint accounts for this variation or use the heat trace curve function.
- ✓ Test for correct current measurement.
- ✓ For parallel resistance heating cable, check for broken cable, failed splice or tee connection.
- ✓ For zone-type heating cable, check for failed zones.

LOWVOLTAGE ALARM
---------------------

The measured circuit voltage is less than or equal to the Low Voltage Alarm setpoint.

- ✓ Check for voltage input failure by measuring the voltage at the Heater Voltage terminals.
- ✓ If a control transformer is used for input power, check the wiring configuration to the transformer.
- ✓ Check loading on power system. Possible brown out.

**Warning Alarms**

ALARMDURING TRACECHECK
---------------------------

One of the following alarms occurred during the TraceCheck™ cycle. Refer to the alarm details above for the individual alarm.

- ✓ TC SWITCH SHORTED ALARM
- ✓ TC LOSS OF CONTINUITY
- ✓ TC HIGH CURRENT ALARM
- ✓ TC LOW CURRENT ALARM
- ✓ TC GROUND FAULT ALARM
- ✓ TC GROUND FAULT TRIP

**Reset Alarms**

Some alarms such as TraceCheck type, Ground Fault Trip and Ground Fault test are latching. The alarm remains on the display even after the alarm condition has gone away. Latch alarms require you to acknowledge or reset the alarm.

To reset alarms,

1. Press [STATUS].
2. Press [MESSAGE D-] to locate the alarm message.
3. Press [RESET].

The alarm should be cleared from the display unless the alarm condition is still present.

## Overview

The MS-2102 heat trace controller communicates with computerized equipment such as programmable logic controllers, desktop computers or man-machine interfaces using Modicon Modbus protocol. The MS-2102 supports a subset of the Remote Terminal Unit (RTU) format of the protocol that provides extensive monitoring, programming and control functions using read and write register commands. The MS-2102 always acts as a slave device such that it does not initiate communications; it only listens and responds to requests issued by a master computer.

## Physical Layer

Modbus protocol is hardware independent so that the physical layer can be a variety of hardware mediums such as RS-485, RS-422, RS-232 or fiber optics. The MS-2102 is configured with one RS-485 port. Refer to *Chapter 2 Installation*, for wiring details.

Each data bit is transmitted in an asynchronous format consisting of 1 start bit and 1 stop bit to produce a 10-bit data frame. This is important for transmission through Modems at higher bit rates (11 bit frames are not supported by some Modems at bit rates greater than 300bps). The baud rate on the serial port is programmable. Baud rates of 1200, 2400, 4800 and 9600 are available. Parity is fixed to *none*. Refer to *Chapter 6 Setpoint Values*, for details on baud rate configuration.

The master device must know the address (module number) of the slave device in order to communicate with it. The MS-2102 does not respond to requests from the master unless the request matches the controller's module number. Refer to *Chapter 6 Setpoint Values*, for details on setting the module number.

## Modbus Protocol

This section discusses the Modbus protocol.

**Data Structure:** Data communications take place in packets, which consist of multiple asynchronously framed data. The master sends a packet to the slave and the slave responds with a packet. End of packet is determined by a **dead time** on the data highway.

Modbus packet Format:

Slave Address:	1 byte
Function Code:	1 byte
Data:	<i>N</i> bytes
CRC:	2 bytes
Dead Time:	3.5 bytes transmission time

**Slave Address:** This is referred to as module number on the MS-2102 that is to receive packets sent by the master and respond to the request. The module number must be unique for each controller on the data highway to avoid bus contention. The module number is user definable

from 1 to 250; refer to *Chapter 6 Setpoint Values* for details. Only the addressed slave responds to a packet that starts with its module number.

**Function Code:** The function code tells the slave what action to perform. Refer to supported functions in this section for details.

**Data:** The number of bytes depends on the function code. Data include setpoints, Measured Values, or alarm status or addresses sent between the master and slave.

**CRC:** Short for Cyclic Redundancy Check, CRC is an industry standard method used for error detection. Modbus RTU includes a 16-bit CRC with every packet. When a slave receives a packet that is in error due to CRC the slave device ignores the packet to prevent any erroneous operation.

**Dead Time:** End of transmission of a packet is determined when no data is received for a period of 3.5 byte transmission times (about 15ms at 2400 baud and 4ms at 9600 baud). Consequently, the transmitting device must not allow gaps between bytes longer than this interval. Once the dead time has expired without a new byte transmission, all slaves start listening for a new packet from the master except the addressed slave.

**Supported Function Codes:** The following functions are supported by MS-2102 firmware:

CODE	Address Range	Type	Interpretation
03	40001-50000	Holding Register	Read variable registers
05	1-10000	Output Coil	Reset heater alarm or statistics
06	40001-50000	Holding Register	Store value into one variable register
16	40001-50000	Holding Register	Store value into a group of variable registers

*Note: Any slave module must have a unique address within 1 - 250. Address 255 is reserved for module commissioning & addressing.*

### Function code 03 - Read Variable Registers

Modbus implementation: Read Holding Registers

MS-2102 implementation: Read variable registers

In Modbus, Read Holding Registers is used to obtain current binary value in one or more holding registers.

It assumes that each register is a 16-bit register. For the MS-2102 implementation of Modbus, this function obtains value from one variable register or values from a group of variable registers.

This command can access only the variable registers with Memory Location Index between 0 (the first index in Module Setup Group) and 164 (the last index in Heater Statistics Group). Any attempts to read a variable register with Memory Location Index beyond the above range results in an error response in return.

**Master Query:** It consists of module address, function code, memory location index of the starting variable register, number of variable registers to be read and CRC error check.

**Slave Response:** It consists of module address, function code, quantity of data bytes to be returned, data value and CRC error check.

**Message Format and Example:**

Request slave 11 to respond with local heater #1's low current alarm level. Suppose heater #1's low temperature alarm level is 10.1 °C. Here are transmission and response messages:

Master Transmission	Bytes	Message Contents (Decimal)
Slave Address	1	11 (message to slave 11)
Function Code	1	3 (command "read variable registers")
Memory Location Index	2	73 (refer to register storing local heater #1's low temp level)
Number of Registers	2	1 (a 2-byte variable)
CRC	2	????

Slave Response	Bytes	Message Contents (Decimal)
Slave Address	1	11 (message from slave 11)
Function Code	1	3 (command "read variable registers")
Quantity of Data Bytes	1	2 (2 bytes)
Data Value	2	101 (10.1 °C)
CRC	2	????

**Function code 05 - Reset Heater Alarms & Statistics**

Modbus implementation: Force Single Coil

MS-2102 implementation: Reset heater alarms & statistics

In Modbus, Force Single Coil forces logic coil to a state of ON or OFF.

For the MS-2102 implementation of Modbus, this function resets the heater alarm or statistics. Once an MS-2102 control module is in use, it keeps monitoring heater alarms and updating heater statistics. Some of the alarms are latched even after the alarm condition no longer exists. It's up to the user to reset those latched alarms and some statistics. By sending a data value 65280 (FF00 Hex) to any variable register with Memory Location Index between 165 and 186 (Heater Alarm Reset & Statistics Reset Group), the corresponding alarm or statistics will be reset. Sending a data value 0 to any register within the above range is legal but will have no effect. Sending a data value other than 65280 and 0 to any register within the range or sending any data to any register beyond the range is illegal and will result in an error response in return.

**Master Query:** It consists of module address, function code, memory location index of the variable register, data value FF00 Hex and CRC error check.

**Slave Response:** It consists of module address, function code, memory location index of the variable register, data value FF00 Hex and CRC error check.

**Message Format and Example:**

Request slave 200 to reset local heater #10's minimum temperature. Here are transmission and response messages:

Master Transmission	Bytes	Message Contents (Decimal)
Slave Address	1	200 (message to slave 200)
Function Code	1	5 (command "reset heater alarm and statistics")
Memory Location Index	2	173 + (10-1) * 190
Data Value	2	65280 (FF00 Hex)
CRC	2	????

Slave Response	Bytes	Message Contents (Decimal)
Slave Address	1	200 (message from slave 200)
Function Code	1	5 (command "reset heater alarm and statistics")
Memory Location Index	2	173 + (10-1) * 190
Data Value	2	65280 (FF00 Hex)
CRC	2	????

**Function code 06 - Store a Value into one Variable Register**

Modbus implementation: Preset Single Register

MS-2102 implementation: Store a value into one variable register

In Modbus, Preset Single Register places a specific binary value into a holding register. For the MS-2102 implementation of Modbus, this function is used to store a value into one variable register with Memory Location Index in Module Setup Group (0 to 30), Module Setting Group (31 to 43) and Heater Setpoints Group (71 to 108). Any attempts to store a value into a variable register beyond the above range results in an error response.

**Master Query:** It consists of module address, function code, memory location index of the variable register, data value and CRC error check.

**Slave Response:** It consists of module address, function code, memory location index of the variable register, data value and CRC error check.

**Message Format and Example:**

Request slave 98 to change its local heater #10's heater setpoint to 30 °C. Here are transmission and response messages:

Master Transmission	Bytes	Message Contents (Decimal)
Slave Address	1	98 (message to slave 98)
Function Code	1	6 (command "store a value into one variable register")
Memory Location Index	2	72 + (10-1) * 190
Data Value	2	300 (30.0°C)
CRC	2	????

Slave Response	Bytes	Message Contents (Decimal)
Slave Address	1	98 (message from slave 98)
Function Code	1	6 (command "store a value into one variable register")
Memory Location Index	2	72 + (10-1) * 190
Data Value	2	300 (30.0°C)
CRC	2	????

### Function code 16 - Store Values into a Group of Variable Registers

Modbus implementation: Reset Multiple Registers

MS-2102 implementation: Store values into a group Variable registers

In Modbus, Preset Multiple Registers places specific binary values into a series of consecutive holding registers. It assumes that each register is 16-bit register. For the MS-2102 implementation of Modbus, it is the same thing. Using this command, a group of consecutive variable registers can be assigned to their desired values. This command can access only the variable registers with Memory Location Index in Module Setting Group (31 to 43) and Heater Setpoints Group (71 to 108). Any attempts to store values into variable registers with Memory Location Index beyond the above range results in an error response in return.

Master Query: It consists of module address, function code, memory location index of the starting variable register, number of variable registers to be stored, quantity of data bytes to be stored, data value and CRC error check.

Slave Response: It consists of module address, function code, memory location index of the starting variable register, quantity of data bytes stored and CRC error check.

Message Format and Example:

Request slave 11 to set local heater #1's low temperature alarm level to 5 °C and high temperature alarm level to

Master Transmission	Bytes	Message Contents (Decimal)
Slave Address	1	11 (message to slave 11)
Function Code	1	16 (command "store value to a group of variable registers")
Memory Location Index	2	73
Number of Registers	2	2 (2 variable registers)
Quantity of Data Bytes	1	4 (4 bytes)
Data Value	4	50 (50°C for low temp alm level) 3000 (300°C for high temp alm level)
CRC	2	????

Slave Response	Bytes	Message Contents (Decimal)
Slave Address	1	11 (message from slave 11)
Function Code	1	16 (command "store value to a group of variable registers")
Memory Location Index	2	73
Number of Registers	2	2 (2 variable registers)
CRC	2	????

300 °C. Here are transmission and response messages:

### Module Commissioning & Addressing

A MS-2102 module contains a whole set of setpoints and module settings. It also has its assigned module address.

Any customer equipment (Master) with Modbus communication protocol can reset all heater setpoints and module settings to their default values, read a module's assigned address or assign a new address to a module. It is called Module Commissioning & Addressing. To avoid any careless errors, only the module that is in listening to new address mode (The ADDRESS ENABLE dip switch is set to the enable position) responds to Module Commissioning & Addressing commands.

To perform module commissioning on an MS-2102 module, a Master must use Function 06 to store a value of 0 into the variable register with Memory Location Index 187. To read a module's address, a Master must use Function 03 to read the value stored in the variable register with Memory Location Index 188.

To assign a new address to a module's address, a Master must use Function 06 to store a desired address into the variable register with Memory Location Index 189.

*Note: The slave address of the above module commissioning & addressing commands is fixed to 255.*

Message Format and Example:

Assign a module to a new address 230. Here are transmission and response messages:

Master Transmission	Bytes	Message Contents (Decimal)
Slave Address	1	255 (always 255)
Function Code	1	6 (command "store a value into one variable register")
Memory Location Index	2	189 (refer to the register for assigning address)
Data Value	2	230 (new address)
CRC	2	????

Slave Response	Bytes	Message Contents (Decimal)
Slave Address	1	255 (always 255)
Function Code	1	6 (command "store a value into one variable register")
Memory Location Index	2	189 (refer to the register for assigning address)
Data Value	2	230 (new address)
CRC	2	????

### MS-2102 Error Responses

If an MS-2102 module receives a transmission in which an error is indicated by framing, format, overrun or the CRC calculation, the module will not respond to the

transmission.

When a MS-2102 module detects an error other than a framing, format, overrun or CRC error, a response will be sent to the master. The most significant bit of the FUNCTION CODE byte will be set to 1 (that is the function code sent from the slave will be equal to the function code sent from the master plus 128). The byte that follows it will be an exception code indicating the type of error that occurred.

The slave response to an error (other than CRC error) will be:

Slave Response	Bytes	Message Contents (Decimal)
Slave Address	1	????
Function Code	1	????
Exception Code	1	????
CRC	2	????

The MS-2102 implements the following exception response codes.

**01 - ILLEGAL FUNCTION**

The function code transmitted by the master is not one of the functions supported by MS-2102.

**02 - ILLEGAL MEMORY LOCATION INDEX**

The index transmitted by the master is not allowable.

**08 - ILLEGAL ADDRESS ENABLE DIP SWITCH POSITION**

The address enable dip switch on MS-2102 controller is in the wrong position

**Modbus Memory Map**

Upon request, the Modbus Memory Map can be sent to customers from factory.

**Overview**

You can use the procedures in this chapter to verify the proper operation of the MS-2102. Although not a complete functional verification, these tests will check major operating functions. The scope of testing includes field testing of the controller inputs/outputs with and without heat tracing cable. Before commissioning the controller, read *Chapter 2 Installation*. It provides important information about wiring, mounting and safety concerns. One should also become familiar with the controller as described in *Chapter 3 Getting Started* and *Chapter 6 Setpoint values*.

**Requirements**

The test procedures outlined in this chapter verify functions related to field application. These functions include RTD inputs, heater output, ground fault, current and voltage monitoring. To facilitate field testing, it is recommended functions be turned *off* or *disabled*. It is not mandatory that field testing be done. However, we recommend procedures in section *Placing the Controller in Service* be performed for all installations to verify proper operation and function of the equipment.

**Safety Precaution**



Dangerously high voltages are present on the power input and output terminals capable of causing death or serious injury.



Use extreme caution and follow all safety rules when handling, testing or adjusting the equipment.



The controller uses components that are sensitive to electro-static discharges. When handling the unit, care should be taken to avoid contact with terminal blocks.

**Installation Checks:**

1. Check that the line voltage to the power inputs does not exceed the name plate ratings.
2. Check that the current draw of the heat trace cable does not exceed the name plate ratings.
3. Check that the grounding stud is properly connected to ground.

**RTD Input Test**

Equipment:

Two Resistance Decade Boxes or RTD Simulator

To test RTD Input,

1. Disconnect the RTD(s) from the control module ensuring that the leads are adequately labelled.
2. Connect the resistance box as shown in figure 9.3.

Figure 9.1 Resistance versus Temperature in °C (DIN EN 60751 RTD)

°C	R (ohms)	°C	R (ohms)	°C	R (ohms)
-40	84.27	80	130.89	200	175.84
-30	88.22	90	134.70	210	179.51
-20	92.16	100	138.50	220	183.17
-10	96.09	110	142.29	230	186.82
0	100.00	120	146.06	240	190.46
10	103.90	130	149.82	250	194.08
20	107.79	140	153.58	260	197.69
30	111.67	150	157.32	270	201.30
40	115.64	160	161.04	280	204.88
50	119.39	170	164.76	290	208.46
60	123.24	180	168.47	300	212.03
70	127.07	190	172.16		

Figure 9.2 Resistance versus Temperature in °F (DIN EN 60751 RTD)

°F	R (ohms)	°F	R (ohms)	°F	R (ohms)
-40	84.27	160	127.50	360	169.29
-30	86.47	170	129.62	370	171.34
-20	88.66	180	131.74	380	173.39
-10	90.85	190	133.86	390	175.43
0	93.03	200	135.97	400	177.48
10	95.22	210	138.08	410	179.51
20	97.39	220	140.18	420	181.55
30	99.57	230	142.29	430	183.58
40	101.74	240	144.38	440	185.61
50	103.90	250	146.48	450	187.63
60	106.06	260	148.57	460	189.65
70	108.22	270	150.66	470	191.67
80	110.38	280	152.74	480	193.68
90	112.53	290	154.82	490	195.69
100	114.68	300	156.90	500	197.69
110	116.83	310	158.97		
120	118.97	320	161.04		
130	121.10	330	163.11		
140	123.24	340	165.17		
150	125.37	350	167.23		

3. Choose a test temperature for each RTD input and select corresponding resistances for each of the resistance decade boxes using the table of RTD resistances in figure 9.1 and 9.2. The temperatures for each RTD should be different. For the RTD simulator, set the test temperature of each unit.
4. Turn on power to the controller.
5. Display the temperature of each RTD (MEASURED\OPERATING VALUES\HEATER CONTROL TEMP. The two values should agree with the selected temperatures within the accuracy of the controller and test equipment.
6. If there is a significant discrepancy, consult the factory for service.

**Heater Voltage and Current Test (MS2102 controller only)**

Equipment:

- one voltmeter
- one clamp-on ammeter
- adjustable load bank (240VAC/10kW)
- 240VAC/30A single phase variac

You can perform voltage and current measurement tests on the same test setup. Rather than using an adjustable load, you can use a fixed load in conjunction with a variac to adjust the input supply voltage.

To test heater 1 voltage and current,

1. Disconnect any field wiring to terminals 2,3,4 and 5.
2. Connect the adjustable variac outputs to terminals 2 and 3. Connect the input supply of the variac to

either 208 or 240VAC. 120VAC will work but will not provide an effective test range for voltage testing.

3. Connect the load bank to terminals 4 and 5.
4. Connect the voltmeter across terminals 2 and 3.
5. Connect a clamp-on ammeter around one of the load cables.
6. Set the variac control for 120VAC and turn on the power.
7. Force the heater *on* by setting the manual heater function for **1 hour** (SETPOINT\SETPOINT TEST\MANUAL HEATER).
8. Display the heater current (MEASURED\OPERATING VALUES\HEATER CURRENT).
9. Adjust the variac control within the voltage range of the controller and compare the readings of the display with the ammeter.
10. Display the heater voltage (MEASURED\OPERATING VALUES\HEATER VOLTAGE).
11. Adjust the variac control to take another set of readings. Repeat until enough readings are taken to cover the range. Current and voltage readings should be within the accuracy of the controller and test equipment.
12. If there is a significant discrepancy, consult the factory for service.

The test procedures for heater 2 voltage and current are as same as the above procedures except that the power in/out terminals are 26, 27, 28 and 29. Also, the measured voltage for heater 2 is actually the input voltage of heater 1.

Figure 9.3 Test Setup

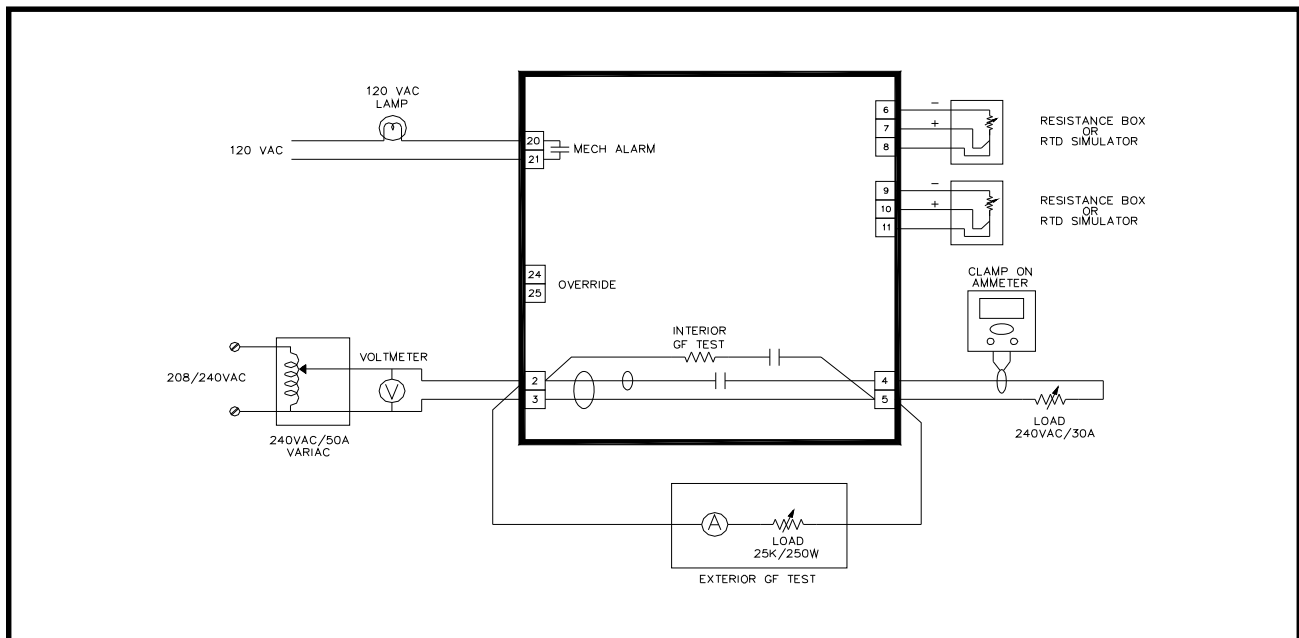

## Ground Fault Current Test

### Internal GF CT Test

The controller comes with a ground fault CT test function that can be executed from the display (SETPOINTS\SETPOINT TEST\GF CT TEST).

To run this test,

1. Select start now
2. Go to ground fault current (MEASURED\OPERATING VALUES\GROUND FAULT CURRENT).

A ground fault current appears for the duration of the test. If a heater does not see a ground fault current, it will initiate a GF CT failure alarm indicating the ground fault monitoring function is not working. The GF CT test function only verifies for operation and does not check for measurement accuracy. To check for accuracy, the next test procedure applies.

### External GF Test

Using the same test setup for voltage and current measurement tests, add the following components to the test setup.

Equipment:

One 240R/250W power resistor (load bank used in previous procedure may be disconnected and used in place)

One AC ammeter (0-1A range)

To test heater 1 ground fault current,

1. Disconnect the load bank used in the previous test and reconfigure to 240R if possible.
2. Connect the load bank or power resistor to terminals 2 and 5 of the controller with the ammeter in series.
3. Set the variac control for 120VAC and turn on the power.
4. Force the heater on by setting the manual heater function for 1 hour (SETPOINT\SETPOINT TEST\MANUAL HEATER).
5. Change the GF trip alarm to **OFF** to prevent nuisance trips during the test. Reset ground fault trip alarms if necessary.
6. Display ground fault current (MEASURED\OPERATING VALUES\GROUND FAULT CURRENT).
7. Adjust the variac control to simulate various levels of ground fault currents through the load and compare readings from the display with the ammeter. Readings should be within the accuracy of the controller and test equipment.
8. If there is a significant discrepancy, consult the

factory for service.

9. Disconnect the load bank after the test.

The test procedures for heater 2 ground fault current are as same as the above procedures except that the load bank or power resistor should be connected to terminals 26 and 29, not 2 and 5.

## Alarm Output Test

### Mechanical Alarm

Equipment:

one 120VAC/100W Incandescent lamp with socket base

To test mechanical alarm contact,

1. Connect one lead of the lamp to terminal 20 of the controller.
2. Connect 120VAC to open lead of the lamp and terminal 21.
3. Power on the controller.
4. Ensure all alarms are turned off so that the controller is in no alarm condition.
5. Set SETPOINTS\SYSTEM SETUP\ALARM CONTACTS to MECH:NO SS:N/A. Lamp should be *off*.
6. Force alarm on by setting SETPOINT\SETPOINT TEST\ALARM TEST to **on for 1 hour**.
7. Lamp should be *on*.

### Override Input Test

Equipment:

one 120VAC Incandescent lamp

To test override input,

1. Connect the 120VAC incandescent lamp to terminals 4 and 5.
2. Power on the controller.
3. Make sure an RTD or simulator is connected to RTD1 input and set the equipment so that the control temperature is 100°C.
4. Check the heater 1 control temperature located at ACTUAL\OPERATING VALUES\HEATER CONTROL TEMP for 100°C.
5. Set the heater 1 setpoint so that it is greater than the control temperature + deadband at SETPOINTS\OPERATING VALUES\HEATER SETPOINT. The deadband setting is located at SETPOINT\HEATER SETUP\DEADBAND.
7. Heater 1 should be *on*. Verify by checking the lamp is *on*.
8. Set SETPOINTS\HEATER SETUP\MASTER OVERRIDE to **on**.

9. Heater 1 should now be *off*. Verify by checking the lamp is *off*.
10. Short override input, terminals 24 and 25 with a short piece of wire.
11. Heater 1 should be *on*. Verify by checking the lamp is *on*.

## Placing the Controller in Service

### Programming Setpoints

Before testing the controller with heat trace cables, program setpoints. Ensure the program enable dip switch is set to ENABLED position. It is recommended that you program setpoints in the operating values group. For users who are not familiar with the control functions, advanced functions such as those in the heater setup group should be disabled during initial startup to simplify troubleshooting.

### Initial Startup

After programming setpoints in the operating values group, the controller is ready for test. Check field connections to make sure they are correctly wired. Power on the controller and check the control temperatures on the display (MEASURED\OPERATING VALUES\HEATER CONTROL TEMP). Verify that the temperature readings are valid.

Assuming a heater circuit's pipe temperature is below the setpoint, the heater should be calling for heat.

Check heater voltage (MEASURED\OPERATING VALUES\HEATER VOLTAGE) on the display to verify with the line voltage.

Check heater current (MEASURED\OPERATING VALUES\HEATER CURRENT) on the display. If the controller is calling for heat, this value should be greater than zero; otherwise, a low current alarm appears. This is an indication the heater is not properly wired or functioning correctly. The display value should correspond to the expected current draw of the heat trace.

### Startup Problems

#### Breaker Trip Due to Inrush:

If self-regulating heat trace is used, it is possible the display will show O.L. (overload) because of the in-rush current exhibit in the heat trace during cold startup. The heater current range is up to 30A so that you can monitor inrush current. The heater current drops as the pipe temperature warms up. If the circuit breaker trips during startup, the inrush current is too high for the breaker rating. Check the heat trace design to make sure the

breaker rating is appropriately sized. Turn on the STAGGER START function to reduce the inrush current.

#### Ground Faults:

Check ground fault current (MEASURED\OPERATING VALUES\GROUND FAULT CURRENT) on the display. Ground fault current should not be over 15mA; otherwise, ground fault trip or alarm appears on the display. To troubleshoot ground faults, check heat trace wiring and moisture in electrical junction boxes and connections.

#### Low and High Current Alarms with Self-Regulating Cable:

Setting values for low and high current alarms with self-regulating cable is more complicated since the heater output varies with temperature. High current alarms may occur during startup due to inrush currents and low current alarms may result when steady-state current is reached (pipe temperature is near setpoint). To prevent nuisance high and low current alarms, the high current alarm should be turned off and low current alarm set below the current rating of the cable at setpoint temperature.

#### Low Temperature Alarm:

During startup, a low temperature alarm is expected as cold fluid in the pipe slowly warms up. As the pipe temperature increases and exceeds the low temperature alarm setting, the alarm turns off. Eventually, the pipe temperature reaches setpoint, at which point the heater turns off. If the low temperature alarm and heater is on consistently, it is possible the heat tracing is not supplying enough heat. Either a higher wattage heat trace or longer length is required.

#### High Temperature Alarm:

A high temperature alarm occurs when pipe temperature exceeds the high temperature alarm setting. This can be caused by high feed temperature of the fluid. Placement of the RTD sensor near a hot area or direct exposure to sunlight may also cause a high temperature alarm. In this situation, improper pipe heating results..

### Power Limiting

You can use power limiting when the total wattage of the heat trace cable is not required or to limit inrush current to the self-regulating cable. The power limit function is located at SETPOINT\HEATER SETUP\POWER LIMIT. A detail explanation of how this function operates is described in the *Chapter 1 Theory of Operation*. Power limiting is set by the desired operating current of

the heat trace. For power limit to work properly, the power limit current should be below the nominal current rating of the heat trace. For example, if the heat trace draws 20A at its rated voltage and the application only requires 75% of its rated output, a power limit current of 15A will achieve a 75% reduction in power. With the power limit current set, the controller attempts to clamp the output current at that value.

The minimum power limit current setting should be greater than 10% of the nominal load current. This is because power limiting operates in 10% resolution. Choosing a power limit current below 10% causes the heater not to turn on since the average heater current at 10% (minimum duty cycle) exceeds the power limit current setting.

Be aware of how current alarms operate with duty cycle changes. Low current alarm is based on the nominal current ratings of the heat trace, not the average current. The low current alarm function converts actual current readings to the expected current value of the heat trace operating at 100% duty cycle prior to comparing against alarm settings. When using power limit, the high current alarm is disabled to prevent false alarms due to measurement error of the algorithm at low duty cycles. The error is always positive and therefore does not affect low current alarms.

### Control Scheme

The MS-2102 controller supports two types of control scheme: on/off and proportional. The default is on/off switching which is used for majority of the applications. When on/off switching is used, the deadband setting determines the heater turn off temperature above the heater setpoint and the heater turn on temperature below the heater setpoint. The deadband setting is user definable located at SETPOINTS\HEATER\SETUP\DEADBAND. In applications requiring tighter control, you can use proportional control. To enable proportional control, locate message SETPOINTS\HEATER\SETUP\PROPORTIONAL CONTROL. There is no proportional gain setting as this is automatically set by the controller to minimize errors. For further details how the proportional control function operates, refer to *Chapter 1 Theory of Operation*.

### RTD

In the event of complete RTD failure, the controller can force the heater to default on or off. This is defined by message SETPOINT\HEATER SETUP\IF RTD FAILS

HEATER GOES. The choice of **on** or **off** depends on the application.

### Cost of Power

In order for the energy cost functions to provide correct information, you should enter the cost per KWh for electrical power at SETPOINT\SYSTEM SETUP\COST PER KWh.

### Completing the Installation

At this point, the controller has been setup with enough information to control and monitor the heat trace. Other functions are less critical and a description on how these functions operate is located in *Chapter 6 Setpoint Values*. Read chapter 6 to gain an understanding of all the functions in order to customize the controller to the application requirements.

**Ethernet Communication in BACnet/IP and MS-2102 Model Option “BAC/BAC1”**

In *Figure 10.1*, BACnet/IP communication is added to MS-2102 heat tracing controller by MasterTrace Modbus to BACnet/IP gateway. The gateway (ex. BB3-7101 from Control Solutions, or FS-EZ1-MOD-BAC from Sierra Monitor) is interfacing a MS-2102 Modbus RTU control module to a BACnet/IP network. The gateway automatically polls the MS-2102 Modbus RTU control module at 9600 baud rate and stores the polling registers’ content to their respective configured BACnet objects. The Modbus RS485 side can connect to the serial port of MS-2102 control module over long distances (up to 4000 feet). Through Ethernet cable, the gateway presents a BACnet device object to the BACnet/IP network. This single BACnet device object could consist of up to 5000 data objects, enough to cover every Modbus register in MS-2102. A BACnet management system, such as building automation system, BACnet network discovery tool, or BACnet explorer, may then use standard BACnet services such as Read Property to access of the content of a read-only data object/Modbus register, or Write Property to change the content of a readable & writable data object/Modbus register.

**BAC**, an additional option, has been added to the MS-2102 heat tracing controller model options to allow customers to purchase Nextron MS-2102 heat tracing controller with BACnet/IP communication capability. **BAC1** is another option for gateway mounted in an FRP enclosure. Refer to *Chapter 1 Product Overview* for MS-2102 Models.

*Figure 10.1 BACnet/IP Communication*

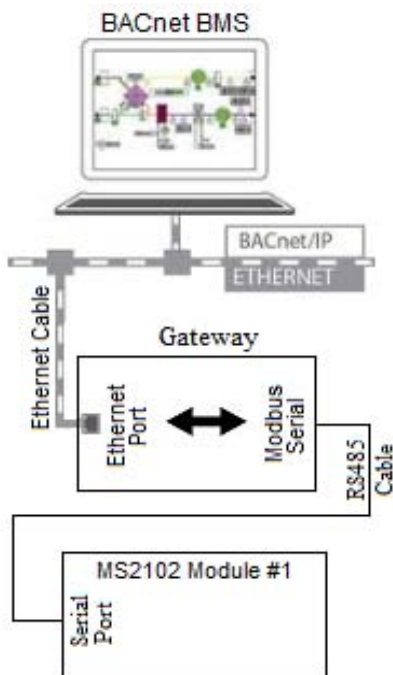

In a MS-2102 heat tracing control module with **BAC/BAC1** option, the MasterTrace Modbus to BACnet/IP gateway, as shown in *Figure 10.2*, is an assembled electronic unit, separated from MS-2102 module. It can be located as far as 4000 feet away from the module. To install it, use a 2 wire power cord to feed power to the unit and a RS485 cable to connect the unit and serial port of the MS-2102 module. An Ethernet cable is needed to connect the unit to Ethernet network. In this way, the gateway with default IP 172.19.24.180 joins the BACnet/IP communication network.

*Figure 10.2 Configured Modbus to BACnet/IP gateway*

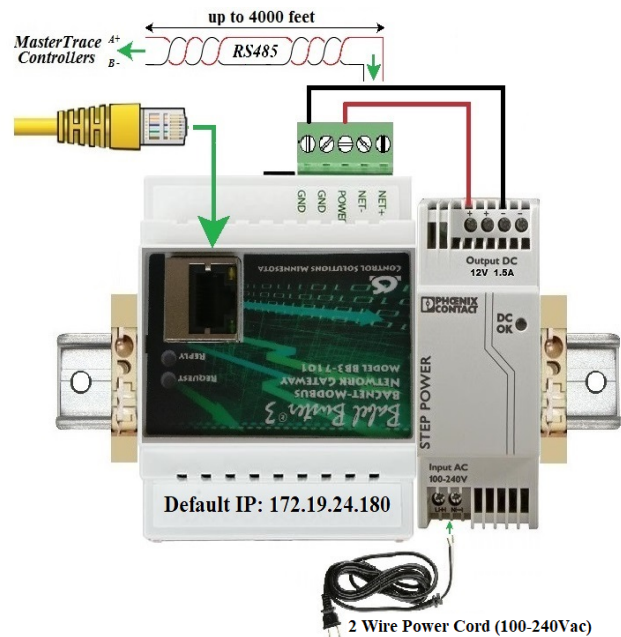

*Configured MasterTrace Modbus to BACnet IP Gateway*

The gateway in *Figure 10.2* is BB3-7101 or BB2-7010-01 or BB2-7010-01-10X from Control Solutions. There is a built-in web server “Babel Buster 3/2” with default IP 172.19.24.180 that can be accessed via web browser with user name and password. Through the web server, customer can configure various BACnet objects of interest. Three types of objects are commonly interested in MasterTrace heat tracing controller. They are analog input object, binary input object, and analog value object. (1) Analog input objects are created to poll their assigned modbus registers for heater measurement values such as RTD temperature, heater current, and ground fault current. (2) Binary input objects are created to reflect the binary signals of heater on/off status, heater alarm status, and specific alarm flags. They are constructed by extracting their specific bit within the heater status register 40110 (4 bytes) or heater alarm status register 40112 regularly polled from MS-2102 heat tracing module. (3) Analog value objects are created to monitor operation setpoints of interest, such as heater enable and heater setpoint. These

writable objects can be updated via the HMI interface in the building management system.

Coming out of Nextron factory, the following BACnet objects are configured in BB3-7101 or BB2-7010-01 or BB2-7010-01-10X Modbus to BACnet/IP gateway for Nextron-built MS-2102 heat tracing controller with model option *BAC/BACI*.

- Heater 1-1 Temperature (in unit of tenth of 1°C)*
- Heater 1-1 Current (in unit of 10mA)*
- Heater 1-1 GF Current (in unit 1mA)*
- Heater 1-1 On/Off status*
- Heater 1-1 Alarm Status*
- Heater 1-1 low temp alarm*
- Heater 1-1 high temp alarm*
- Heater 1-1 low current alarm*
- Heater 1-1 high current alarm*
- Heater 1-1 ground fault trip alarm*
- Heater 1-1 ground fault alarm*
- Heater 1-1 RTD A failure alarm*
- Heater 1-1 RTD B failure alarm*
- Heater 1-1 output SCR failure alarm*
- Heater 1-1 Tracecheck GF alarm*
- Heater 1-1 Tracecheck lo current alarm*
- Heater 1-1 Tracecheck hi current alarm*
- Heater 1-1 Tracecheck GF trip alarm*
- Heater 1-1 Tracecheck SCR fail alarm*
- Heater 1-1 low voltage alarm*
- Heater 1-1 high voltage alarm*
- Heater 1-1 high current trip alarm*
- Heater 1-1 GF CT test alarm*
- Heater 1-1 Enable*
- Heater 1-1 Heater Setpoint*
- Heater 1-2 Temperature*
- Heater 1-2 Current*
- Heater 1-2 GF Current*
- Heater 1-2 On/Off status*
- Heater 1-2 Alarm Status*
- Heater 1-2 low temp alarm*
- Heater 1-2 high temp alarm*
- Heater 1-2 low current alarm*
- Heater 1-2 high current alarm*
- Heater 1-2 ground fault trip alarm*
- Heater 1-2 ground fault alarm*
- Heater 1-2 RTD A failure alarm*
- Heater 1-2 RTD B failure alarm*
- Heater 1-2 output SCR failure alarm*
- Heater 1-2 Tracecheck GF alarm*
- Heater 1-2 Tracecheck lo current alarm*
- Heater 1-2 Tracecheck GF trip alarm*
- Heater 1-2 Tracecheck SCR fail alarm*
- Heater 1-1 low voltage alarm*
- Heater 1-1 high voltage alarm*
- Heater 1-2 high current trip alarm*
- Heater 1-2 GF CT test alarm*
- Heater 1-2 Enable*
- Heater 1-2 Heater Setpoint*

As mentioned above, field customers can use proper user name and password to access the built-in web server “Babel Buster 3/2” in the gateway with default IP

172.19.24.180 through any web browser to configure more BACnet objects of their interests on other additional MasterTrace heat tracing control modules, as long as (1) serial ports of all control modules are connected in daisy-chain fashion; (2) each control module is with a unique module number and at 9600 baud rate; (3) the total number of objects does not exceed the limit of 5000/1000.

**Serial Communication in BACnet MS/TP network**

In *Figure 10.3*, serial communication in BACnet MS/TP protocol is added to a group of 4 MasterTrace heat tracing control modules by Babel Buster BB2-3010, a BACnet MS/TP to Modbus Serial gateway from Control Solutions. The gateway has 2 sides. The Modbus Serial side can connect to the serial ports of MasterTrace control modules over long distances (up to 4000 feet) at 9600 baud rate. The USB Port side connects to MS/TP-Modbus gateway configuration tool from Control Solutions through a special USB MS/TP adapter (MTX002). This configuration tool is a software interface where customers can configure various BACnet objects. Three types of objects are commonly interested in MasterTrace heat tracing modules. They are analog input object, binary input object, and analog value object. (1) Analog input objects are created to poll their assigned modbus registers for heater measurement values such as RTD temperature, heater current, and ground fault current. They are non-commandable objects. (2) Binary input objects are created to reflect the binary signals of heater on/off status, heater alarm status, and specific alarm flags. They are constructed by extracting their specific bit within the heater status register 40110 (4 bytes) or heater alarm status register 40112 regularly polled from MasterTrace heat tracing modules. (3) Analog value objects are created to monitor operation setpoints of interest, such as heater enable and heater setpoint. They are commandable objects. The BB2-3010 supports up to 300 non-commandable objects, or up to 135 commandable objects, or a mix in between.

*Figure 10.3 BACnet MS/TP Communication*

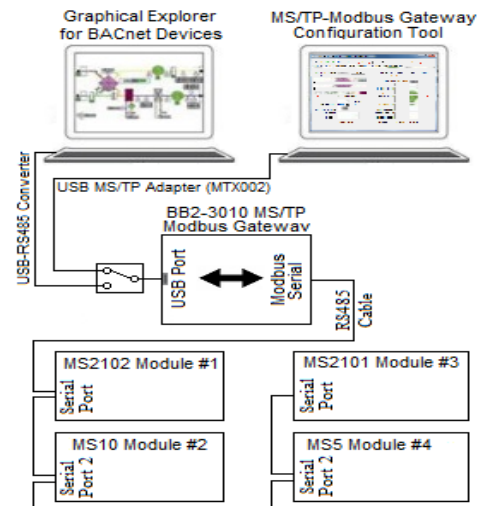

Upon successful configuration, the gateway will constantly update all the configured objects with data polled from their assigned modbus registers in the targeted MasterTrace control modules at the specified intervals. Through a USB-RS485 converter (or MTX002 in passthru mode) on its USB port, the gateway presents a number of live BACnet objects to the BACnet MS/TP network. A BACnet MS/TP supervisory controller or graphical explorer for BACnet devices may then use standard BACnet services such as Read Property to access of the content of a read-only data object/Modbus register, or Write Property to change the content of a readable & writable data object/Modbus register.

**Ethernet Communication in Modbus TCP and MS-2102 Model Option “ETH/ETH1”**

In *Figure 10.4*, Ethernet communication in Modbus TCP is added to MasterTrace heat tracing control modules by Modbus TCP Ethernet to Modbus Serial gateway. The gateway (ex. GC-NET485-MB from Grid Connect) is a Modbus RS485 serial to Modbus TCP Ethernet converter. The RS485 side can connect to the serial port 2 of MasterTrace control modules over long distances (up to 4000 feet). The Ethernet side converts the serial Modbus

write/read data to/from MasterTrace control modules over Ethernet from anywhere in the plant as long as the Ethernet port on the PLC or Automation system is Modbus TCP supported and is assigned to an IP address that is different to the IP addresses of the gateway and other devices in the Ethernet network. Most of PLCs and Automation systems such as Micro820 from Allen-Bradley and M221 from Modicon do have this kind of Ethernet port as built-in.

**ETH**, an additional option, has been added to the MS-2102 heat tracing controller model options to allow customers to purchase Nextron MS-2102 heat tracing controller with Ethernet Modbus TCP communication capability. **ETH1** is another option for gateway mounted in an FRP enclosure. Refer to *Chapter 1 Product Overview* for MS-2102 Models.

In a MS-2102 heat tracing control module with **ETH/ETH1** option, the Modbus TCP Ethernet to Modbus Serial gateway as shown in *Figure 10.5* is an assembled

*Figure 10.4 Modbus TCP Ethernet Communication*

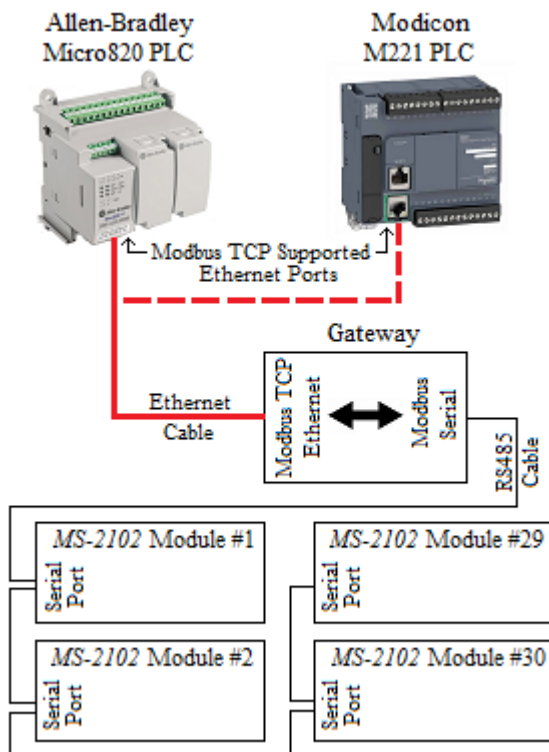

data stream to Modbus TCP Ethernet packets.

Connect a PLC or Automation system to the gateway through its Ethernet port and use it as the Master in the network. You can program the Master according to MasterTrace Modbus Communication Protocol to

*Figure 10.5 Configured Ethernet to Modbus Serial Gateway*

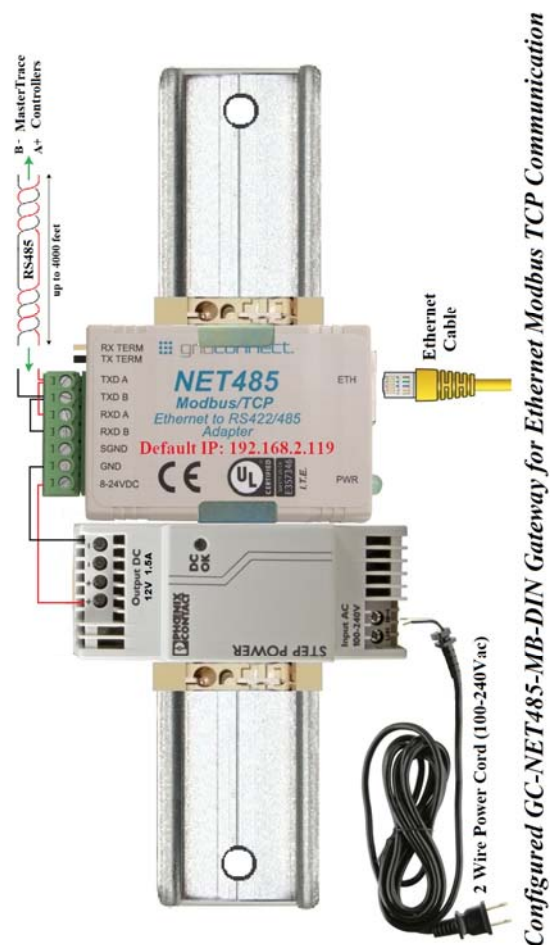

*Configured GC-NET485-MB-DIN Gateway for Ethernet Modbus TCP Communication*

electronic unit, separated from MS-2102 module. It can be

located as far as 4000 feet away from the module. To install it, use a 2 wire power cord to feed power to the unit and a RS485 cable to connect the unit and serial port of the MS-2102 module. Coming out of Nextron factory, the IP address of the gateway (GC-NET485-MB from Grid Connect) has been assigned to 192.168.2.119, and its serial port baud is set to 1200. An Ethernet cable is needed to connect the unit to Ethernet network. In this way, the gateway joins the Ethernet communication network of the PLC or Automation system.

### **An Important Note on Ethernet Gateways**

In Figure 10.2 and 10.5, the same power supply from Phoenix Contact (Phoenix Contact 2868567, 8-24Vdc output, Din Rail, Class 1 Div 2) is used in both units of assembled Ethernet gateway. Its input power voltage range is 100-240Vac. This makes it possible to locate the gateway unit beside the MS-2102 module and utilize the power from MS-2102 to feed the power supply from Phoenix Contact, as long as the MS-2102's input voltage is in a range of 100-240Vac. Use a pair of 14 AWG wires to connect MS-2102's terminal 2 & 3 to terminal L(+) & N(-) of the Phoenix Contact power supply, respectively. In this scenario, due to the limitation of maximum Ethernet cable length, the gateway can only be located less than 100 meters away from the Ethernet network hubs.

## Warranty

The manufacturer warrants each control that it manufactures to be free from defective material or workmanship for a period of 12 months from date of purchase.

Under this warranty, the obligation of the manufacturer is limited to repairing or replacing the defective control at its option, when returned to the manufacturer's factory with shipping charges prepaid.

If failure has been caused by misuse, incorrect application or alteration of the control, this warranty will be void.

**UNLESS SPECIFICALLY PROVIDED FOR IN WRITING IN THIS WARRANTY, EACH CONTROL IS PROVIDED WITHOUT ANY WARRANTY OF ANY KIND EITHER EXPRESSED OR IMPLIED. IN PARTICULAR, WITHOUT LIMITING THE GENERALITY OF THE FOREGOING, THE FOLLOWING IMPLIED WARRANTIES AND CONDITIONS ARE EXPRESSLY DISCLAIMED:**

- a). **ANY IMPLIED WARRANTY OR CONDITION THAT THE CONTROL WILL MEET YOUR REQUIREMENTS.**
- b). **ANY IMPLIED WARRANTY OR CONDITION THAT THE OPERATION OF THE CONTROL WILL BE UNINTERRUPTED OR ERROR FREE; AND**
- c). **ANY IMPLIED WARRANTY OR CONDITION OF MERCHANTABILITY OR FITNESS FOR A PARTICULAR PURPOSE.**

The user shall be made aware that if the equipment is used in a manner not specified by the manufacturer, the protection provided by the equipment may be impaired.

**MASTERTRACE™  
HEAT TRACING CONTROL**

Nexttron A Division of Powell 6120 11<sup>th</sup> Street S.E., Calgary, Alberta, T2H 2L7, Tel: (403) 735-9555, Fax: (403) 735-9559

---

P/N: 1501-0019 MS-2102 04/18 Printed in Canada