

# MasterTrace

HEAT TRACING SYSTEMS

## MasterTrace ADVANTAGES

- Custom engineered control panels
- Easy to read Interface, 2x16-character alphanumeric display, field mounted or remote mounted
- Modbus® communication
- RS 485 serial port connections
- TraceCheck™ early warning system
- Power limiting
- Load shedding
- Solid state or mechanical switching units
- Plant wide Windows-based monitoring software
- Links to PLC's or DCS
- Custom engineered software designs

### Configurations built to individual customer needs:

- Stand alone control or multi-point control panels
- Custom configured software interface for local, remote, or centralized control and monitoring



SAI GLOBAL



MasterTrace Heat Tracing Systems are designed to be the very best in electrical heat trace control and monitoring for industrial applications.

**Custom engineered control panels designed to your specific requirements incorporate the unequalled quality and reliability of Nextron's MasterTrace control modules.**

### The Best in Monitoring

MasterTrace Heat Tracing Systems maximize the performance and reliability of any electrical heat tracing application. Sensing all critical heat trace variables and using the advanced algorithms of its microprocessor, MasterTrace controllers warn you of potential problems before they become critical and maintain your heat trace system 24 hours a day, 365 days of the year.

MasterTrace controllers continuously monitor your heat tracing system and provides you with user-settable alarms for temperature, heater current and ground fault current, all independent of the trip levels. Your heat tracing system is critical to your plant operations so



MasterTrace Systems are designed to perform self-check monitoring on all RTD's and switches.

To further ensure that your heat trace works when you need it, Nextron's TraceCheck™ feature periodically energizes and checks for alarm conditions on all dormant lines and latches onto alarm functions.





# MasterTrace Advantages

## FEATURES AND BENEFITS

**TraceCheck™ Early Warning**  
Alerts operators to problems even when the circuit is not in use.

**Modbus® Protocol**  
Allows easy interfacing with our MC-100 software or PLC and DCS systems.

**Alarm Outputs**  
Common alarm alerts users to problems.

**Centralized Interfacing**  
No need to move around the plant. All variables are monitored at a single location.

**Statistics Monitoring**  
Save energy by monitoring peak demand times.

**Staggerstart**  
Limits initial start up power.

**Proportional Control**  
Provides tight process temperature control.

### Advanced Control

The advanced features of MasterTrace allow it to handle single-phase to three-phase heat trace applications with switch ratings up to 100A@ 600VAC. Integral user-settable ground fault trip protects your heat trace without costly ground fault breakers. The user-settable Ground Fault test function lets you know if Ground Fault monitoring is functioning properly. RTD inputs (dual RTD inputs available) have a user-settable fail-safe strategy. A Master Override input allows for external control for load-shedding or ambient control.

### Friendly Interfacing

MasterTrace interfaces make interrogation and programming easy for all MasterTrace controllers.

Two choices are available:

- Local Interface (ML100)
- Remote Interface (MR100)

ML100 communicates with a single controller of up to 10 circuits and up to five feet away. MR100 communicates with multiple controllers, up to 30 controllers or 300 circuits, to a maximum of 4,000 feet without repeaters.

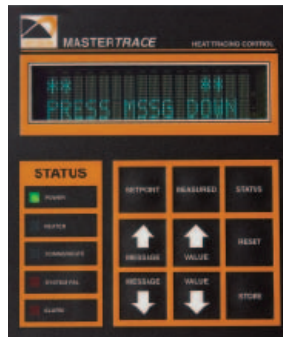

### Energy Management

Operators have many reasons to reduce their environmental impact yet may be missing substantial opportunities to become greener without making significant investments. Opportunities for energy savings are in, perhaps, the most obvious of places – the plant. Monitoring energy and energy costs are the starting points and MasterTrace provides you with the tools through the measured values of: Heater Utilization, Power Consumption (MWh), and Operating Costs (\$0 to \$1,000,000).

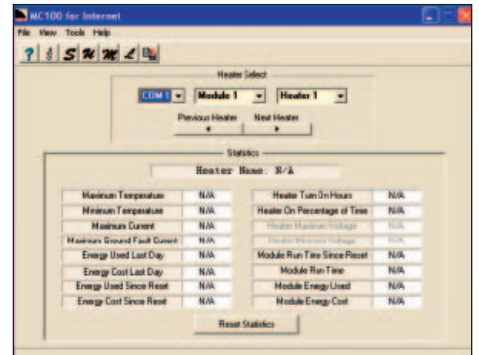

### A System With a Future

MasterTrace is the most complete system of heat tracing controllers. MasterTrace can handle all your heat trace control requirements and is the only heat trace system that offers Local, Group and Central Computer Interfaces (See MC100). MasterTrace combines the power and flexibility you need today with the ability to expand to meet your needs for the future.

### MC100 Centralized Monitoring

For plant wide monitoring, Nextron's MC100 for windows software package provides programming and monitoring for MasterTrace heat tracing controllers on your PC. Process setpoints and alarm levels are programmed for each heater through the computer keyboard reducing data entry on large systems. Setpoint programming and configuration functions are password protected to restrict access. By connecting individual MasterTrace modules or panels together, heat tracing throughout an entire plant can be programmed and monitored from a single location.





# MasterTrace Product Specifications

## APPROVALS

Mechanical:	CSA ordinary (general purpose) areas
Solid-State:	CSA Class I, Division 2, Group A, B, C, D CSA Class I, Zone II Group IIC
Alarm Output:	NO and NC programmable contacts
Alarm Output Rating:	Mechanical: 1.0A @ 120VAC max. (ordinary areas) 10mA @ 30VAC max. (hazardous areas) Solid-state: 0.1A @ 30VAC max.
Control Power:	120VAC
Switch Rating:	Internal: 30A @ 280VAC max. External: 100A @ 600VAC max.
Temperature Input:	One or two 100Ω, platinum, 3-wire RTD per point, 20Ω max. lead resistance ± 0.2A accuracy over -50°C to +500°C
Heater Current Input:	One current transformer per point 3% ± 0.2A accuracy over 1.0A to 100A
Ground Fault Input:	One current transformer per point 5% ± 2mA accuracy over 0.01 to 3.0A
Operating Range:	-40°C to +60°C (LCD screen -20°C to +60°C) VFD vacuum fluorescent display -30°C to +60°C
Communication Ports:	(1) Parallel local interface connection (2) Serial network connections

## SERIAL COMMUNICATIONS

Type:	RS 485
Protocol:	Modbus® RTU
Transmission Rate:	1200-9600 baud
Interconnect:	2-wire, shielded, twisted pair
Highway Distance:	4,000 feet without a repeater
Modules Per Highway:	(1) interface and (30) control modules

## MEASURED VALUES

Temperature:	-50°C to 500°C (-58°F to 932°F)
Minimum Temperature:	-50°C to 500°C (-58°F to 932°F)
Maximum Temperature:	-50°C to 500°C (-58°F to 932°F)
Heater Current:	1.0A to 100A
Heater Percent Power:	0 to 100%
Peak Heater Current:	1.0A to 100A
Ground Fault Current:	0.01A to 1.0A
Heater Utilization:	0 to 100%
Power Consumption:	0 to 1,000 MWh
Operating Cost:	\$0 to \$1,000,000

## ALARM MESSAGES

Temperature:	High temperature alarm Low temperature alarm
Current:	High current alarm Low current alarm High current trip
Ground Fault Current:	Ground fault current alarm Ground fault current trip
TraceCheck™:	Switch shorted High current alarm Low current alarm High current trip Ground fault current alarm Ground fault current trip
Hardware:	Self-check failure, switch shorted RTD open, RTD shorted



## USER-SETTABLE OPTIONS

Heater Status:	Enable or disable
Heater Name or Tag:	16-character alphanumeric
Temperature Units:	°C or °F
Control Strategy:	On-off or proportional*
Deadband:	0° to 50°C (0°F to 90°F)
Stagger Start:*	On or off
Power Limit:*	1.0A to 100A
Temperature Setpoint:	0°C to 500°C (32°F to 932°F)
High Temperature Alarm:	0°C to 500°C (32°F to 932°F)
Low Temperature Alarm:	-50°C to 500°C (32°F to 932°F)
High Current Alarm:	1.0A to 100A
Low Current Alarm:	1.0A to 100A
High Current Trip:	1.0A to 100A
Ground Fault Alarm:	0.01A to 1.0A
Ground Fault Trip:	0.01A to 1.0A
TraceCheck™ Interval:	1 to 24 hours
RTD Fail-Safe:	Heater on or heater off
Master Override:	ON or OFF
Alarm Contacts:	NO or NC for each contact
Alarm Light:	Alarm on, alarm off, Flash during alarm then on, Flash during alarm then off

\* Available on solid-state modules only

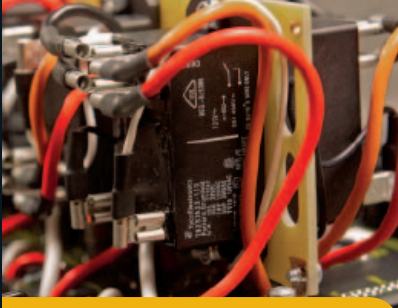

**INNOVATION THAT PROVIDES COST SAVINGS**

In heat trace design, cable and conduit for hard-wired RTD communications represent a large portion of project costs, even on small electrical heat tracing system designs. Wireless data transfer technology is becoming one of the largest areas of growth in industrial plant applications and Nextron is the temperature control systems manufacturer that pairs technical innovation with savings. Nextron offers a CSA approved Class I, Division 2, Zone 2 microprocessor-based RTD sampler capable of transmitting and receiving data using the concept of direct sequence or frequency mode hopping wireless transmission. Using a wireless system, temperature sensors are wired to RTD samplers located in the pipe racks and temperature information is transmitted to the controller via wireless modem, dramatically reducing field-wiring costs to the end user. These transmitters then send temperature information to a remotely located MasterTrace module.

# Nextron Wireless RTD Sampler

## COMMUNICATION MEDIA

- RS485 Cable: Transmit RTD measurements via RS485 cable (Figure 1)
- Wireless RF Modem: Transmit RTD measurements via Wireless RF modems (Figure 2)

## USER INTERFACE

- LED: Power on, RTD OK, transmit, receive
- RS485 Port: Accessible to laptop, PC

## ENVIRONMENT

- Approvals: CSA Class 1, Division 2, Groups A, B, C, D Class 1, Zone 2, Ex nA IIC, AEx nA IIC
- Operating Range: -40°C to +50°C
- Conformal Coating: Boards conformal coated for hostile environments. Altitude: 0-200m

## ENCLOSURE

- Type: NEMA-4 steel
- Size: 10" H x 8" W x 4" D
- Features: Quick release latches to open door One 0.875" conduit knockout for power wiring, two 1.093" conduit knocks for RTD wiring, one 0.75" conduit knock for RS485 cable or antenna

## TEMPERATURE MEASUREMENT RANGE

- Range: -50°C to 500°C, -58°F to 932°F
- Absolute Accuracy: ±2.5°C, ±4.5°F
- Repeatability: ±1°C, ±1.8°F
- RTD: 100-ohm platinum, 3-wire 10 ohms maximum lead resistance

## MODEL

- Configuration: SAM-RTDxx-120V-y  
 xx=10: 10 RTDs  
 xx=20: 20 RTDs  
 y=R: RS485  
 y=M: Wireless

## CONTROL POWER

- Power Requirements: SAM-RTDxx-120V-y: 120VAC, 10VA
- Line Frequency: 50 or 60Hz
- Protection: Protected by non-replaceable 2A, time lag, 350 VAC fuse MOV transient protection and RC snubber

**Figure 1**  
Transmit RTD Measurement Via RS485 Cable

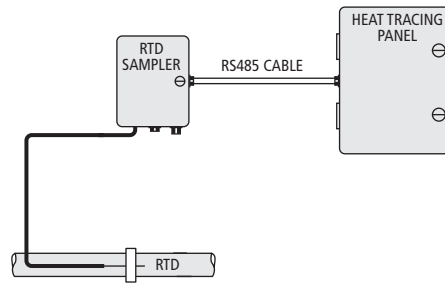

**Figure 2**  
Transmit RTD Measurement Via Wireless RF Modem

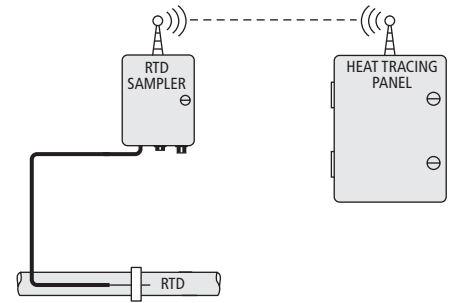

Manufactured by:



#14, 6120 – 11 Street S.E.  
Calgary, Alberta, Canada T2H 2L7

Phone (403) 735-9555  
 Fax (403) 735-9559  
 Toll Free 1-866-639-2875  
 Email sales@nextron.ca

[www.nextron.ca](http://www.nextron.ca)



Scan this code for more information.

The manufacturer believes the information provided by the manufacturer and describing the manufacturer's products is correct. However, users of the manufacturer's information accept all risk of any damages or loss whatsoever that a user may suffer from using the manufacturer's information and the manufacturer's products (including, without limitation, defects in the manufacturer's products), whether the action is based in contract or not (including negligence). Therefore, users should evaluate the product and the suitability of the product for the user's application.

WITHOUT LIMITING THE ABOVE, IN NO EVENT SHALL THE MANUFACTURER BE LIABLE FOR SPECIAL, INDIRECT, INCIDENTAL, CONSEQUENTIAL, EXEMPLARY OR PUNITIVE DAMAGES FOR ANY BREACH OR OUR OBLIGATIONS OR WARRANTIES OF ANY SORT, EXPRESS OR IMPLIED, RESULTING FROM THE USER'S USE OF THE MANUFACTURER'S INFORMATION.

The user hereby agrees to save and hold the manufacturer harmless from any loss, damage, or product liability claim of any sort resulting from the user's use of information or the manufacturer's products.