

TRACEMATE

ELECTRONIC THERMOSTAT

OPERATOR'S MANUAL

1 Product Overview	1.1
Introduction	1.1
Using this Manual	1.1
Features and Benefits	1.1
Conventions	1.1
Specifications	1.2
2 Installation	2.1
Unpacking the Controller	2.1
Control Module	2.1
Mounting the Controller	2.3
Wire Sizing	2.3
Conduit and Cabling	2.3
Power Wiring	2.3
Heater Wiring	2.3
Ground Connection	2.3
RTD Sensor Wiring	2.3
Alarm Wiring	2.4
3 Applications	3.1
Mechanical Thermostat Replacement	3.1
Alarm Annunciator	3.1
Switching Requirements	3.1
4 Operation	4.1
Alarms	4.1
Status Indicators	4.1
Alarm Reset	4.1
Heater Setpoint and Alarm Setpoints	4.1
5 Testing	5.1
Troubleshooting/System Integrity	5.1
Calibration	5.1
Ground Fault Testing	5.2
Repairs	5.2
Warranty	Back Cover

Introduction

The TraceMate solid state heat tracing control is an electronic thermostat designed to maintain a single heater at a desired setpoint temperature. It is suitable for use with mineral-insulated, self-regulating or constant-wattage cable in applications such as freeze protection, process control and instrument tracing. The TraceMate is intended for indoor or outdoor installation in ordinary or class 1, division 2 hazardous locations.

TraceMate offers many advantages over other heat tracing control schemes, which generally use some combination of mechanical thermostats, custom-built panels or programmable controls to provide control, monitoring and alarm functions. Wiring costs are minimized by mounting the control in close proximity to the heat tracing cable and pipe. A NEMA 4X enclosure and wide temperature range electronic components are used to make mounting possible in most locations. Temperature sensing is achieved by mounting a 100 ohm platinum (EN 60751) RTD sensor on the pipe. Heater current is controlled by a solid state switch rated 30A. The temperature setpoint is digital for fast non-ambiguous setting over a wide range. Maximum system reliability is obtained from a comprehensive alarm package which includes indicators for quick fault identification and a ground fault trip to minimize fire hazards.

By combining the control, system monitoring and testing requirements of a heat trace control system into a general purpose control, the TraceMate makes it possible to significantly upgrade systems at low installed cost. In addition, it is very flexible in its application to adapt to specific user requirements. Using dip switch and jumper connection, TraceMate provides users a comprehensive method to adjust heater setpoint, low temperature alarm setpoint, high temperature alarm setpoint, current fail alarm setpoint, and ground fault trip alarm setpoint. Their respective factory default values are:

- Heater setpoint: 20°C**
- Low temp alarm: 5°C**
- High temp alarm: 100°C**
- Current fail alarm: 0.3 A**
- Ground fault trip alarm: 30 mA**

Using This Manual

Detailed information relating to switch and output ratings, accuracy etc. are detailed in *Chapter 1, Product Overview*. *Chapter 2, Installation* discusses important mounting and wiring issues for reliable operation. *Chapter 4, Operation* describes how to setup and operate the controller. The remainder of this manual should be read and kept for reference for optimal performance of the TraceMate.

Features and Benefits

Requirements	TraceMate Features
Temperature Control	<ul style="list-style-type: none"> * 0-511°C/0-511°F setpoint * Non-ambiguous, digital temperature setpoint * 100 ohm platinum RTD sensor * 3-wire, lead resistance compensation
System Fault Alarms	<ul style="list-style-type: none"> * Breaker left off or tripped * Heater continuity or low current * Ground fault trip * Low temperature * High temperature * Broken sensor
Early Warning	<ul style="list-style-type: none"> * Tracecheck exercises dormant systems every 24 hours for early warning to prevent shutdowns * Status indicators show cause of alarms * Separate fail-safe local and remote alarms
Remote Monitoring	<ul style="list-style-type: none"> * Form C alarm dry contact output for digital alarm interface * LED Alarm indicator viewable on door
Hazardous/ Ordinary Area Mounting	<ul style="list-style-type: none"> * CSA approved for ordinary or Class 1, Division 2, Grps A,B,C,D hazardous area * -40° to +50°C operating range * 30 amps @120, 277, 208 or 240VAC rating * Weatherproof, Nema-4X enclosure * Easy retrofit replacement for mechanical thermostat
Low Installed Cost	<ul style="list-style-type: none"> * Competitively priced * Self contained, no control panel to build * Ground fault trip eliminates expensive ground fault circuit breaker * Standard model simplifies spare parts stocking

Conventions

The following conventions are used in this manual:

V~ VAC(AC Volatge)

— — VDC(DC Volatge)

 Warning Statement

Specifications

Temperature Range

Range: -50°C to 500°C, -58°F to 932°F
 Hysteresis: ±2°C, ±3.2°F
 Absolute Accuracy: ±2.5°C, ±4.5°F
 Repeatability: ±1°C, ±1.8°F
 RTD: 100 ohm platinum, 3-wire 20 ohms maximum lead resistance

Heater Switching

Configuration TM-1SIH1-xx: Single-pole, one SCR
 TM-1SIH1-xx-277V: Single-pole, one SCR
 TM-1DIH2-xx: Dual-pole, two SCRs, one per phase
 Ratings: TM-1SIH1-xx: 120Vac @ 30A
 TM-1SIH1-xx-277V: 277Vac @ 30 A
 TM-1DIH2-xx: 208~240VAC @ 30A
 250 amp 1/2 cycle inrush
 Line Frequency 50 or 60Hz

Control Power

Power Requirements Control power from heater voltage
 TM-1SIH1-xx: 120Vac, 10VA
 TM-1SIH1-xx-277V: 277Vac, 10VA
 TM-1DIH2-xx: 208~240VacC, 10VA
 Protection Control power from heater voltage protected by 2A fuse.
 MOV transient protection and RC snubber

User Interface

Heater Setpoint 12 position dip switch
 Reset/Heater Test dip switch
 Panel Indicators Power on
 Heater on
 Low temperature alarm
 High temperature alarm
 Current fail alarm
 Ground fault trip alarm
 RTD fail alarm

Environment

Approvals: CSA NRTL/C and FM
 Class I, Div.2, Groups A,B,C,D
 Class I, Zone 2, Groups IIC
 Operating Range: Single-pole: -40°C to +50°C
 Dual-pole: -40°C to +40°C
 Heater current derated
 Conformal Coating: Boards conformal coated for hostile environments.

User-Definable Options

Heater Setpoint:
 Low Temperature Alarm Setpoint:
 High Temperature Alarm Setpoint:
 0°C-511°C, 1°C steps
 0°F-511°F, 1°F steps
 Temperature Units: 0°C or °F
 Current Fail Alarm Setpoint: 0.0A-30.0A, 0.1 A steps
 Ground Fault Trip Alarm Setpoint: 0mA-511mA, 1 mA steps

Enclosure

Type: E5: Nema-4X steel, painted black
 E3: Nema-4X stainless steel, painted black
 Size: Single-pole: 8"Hx6"Wx4"D
 Dual-pole: 10"Hx8"Wx4"D
 Features: Quick release latches to open door
 One 3/4" conduit knockout for power and two 1/2" conduit knocks for RTD and signal wiring.

Alarms

Low Temperature: Actual temperature < low temperature alarm setpoint **if the alarm is enabled**
 High Temperature: Actual temperature > high temperature alarm setpoint
 Current Fail: Heater current < current fail alarm setpoint
 Ground Fault Trip: Ground fault current > Ground fault trip alarm setpoint
 RTD Fail: RTD Open, RTD Short
 Hardware: No incoming voltage
 TraceCheck: Current Fail Alarm
 Configuration: NC/NO Contacts
 Alarm Output Rating: Form C dry contact: 12-277Vac@ 0.5A, 30VDC/0.1A.
 LED Indicator: 6VDC/50mA

Alarm Function

Temperature: Low Temperature Alarm
 High Temperature Alarm
 Current: Current Fail Alarm
 Ground Fault: Ground Fault Trip
 Hardware: RTD Open, RTD Short

**Heater Current Rating
 1 and 2-Pole Switching**

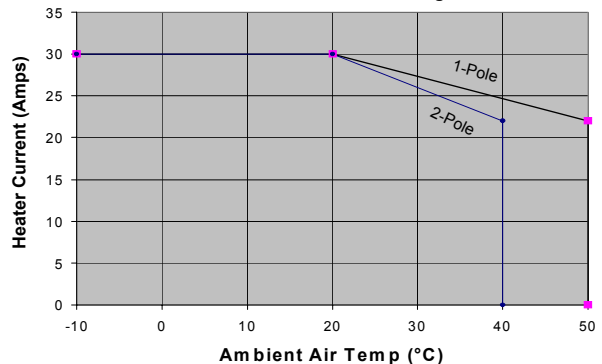

Unpacking the Controller

Check the shipping cartons for damage, or other signs of rough handling or abuse. If damaged, notify the shipping carrier at once.

Carefully remove the TraceMate from the shipping box. Inspect face plate for shipping damage and check electronics for loose wiring or damage. Report any damage to the carrier at once.

Control Module

See *Figure 2.1 TraceMate Controls and Indicator Layout* to locate the following:

Switches and Jumpers

- **S1-9** Setpoint Number:

S1-9 consists of 9 switches. They are S1, S2, S3, S4, S5, S6, S7, S8 and S9. These 9 switches generate a Setpoint Number in a range of 0-511. The exact value of this Setpoint Number equals the sum of the contributions by each switch. If a switch is in **OFF** position, its contribution is zero. If it is in **ON** position, its contribution equals the value labelled on the board.

Ex. 1: If all 9 switches are in the **ON** position,

Setpoint Number = 1 + 2 + 4 + 8 + 16 + 32 + 64 + 128 + 256 = 511.

Ex. 2: If only switches 4 and 16 are in the **ON** position,

Setpoint Number = 0 + 0 + 4 + 0 + 16 + 0 + 0 + 0 + 0 = 20.

- **S10** Temperature Units:

°C if S10 is on °C side. °F if S10 is on °F side.

- **S11** RESET: Latched “Current fail” or “Ground Fault Trip” alarms are cleared when S11 is switched towards the RESET side momentarily if the alarm conditions are no longer exist.

- **S12** TEST: Manually forces heater on when S12 is on TEST side. No effect if the ground fault trip is active.

- **JP1** Jumper Position for Setpoint Configuration:

LT: Setpoint Number generated by S1-9 is interpreted as low temperature alarm setpoint in °C or °F. **If low temperature alarm setpoint is set to 511°C, the alarm is disabled.**

HT: Setpoint Number generated by S1-9 is interpreted as high temperature alarm setpoint in °C or °F.

GF: Setpoint Number generated by S1-9 is interpreted as ground fault trip alarm setpoint in mA.

AMP: Setpoint Number generated by S1-9 is divided by 10 and interpreted as current fail alarm setpoint in A.

SP: Setpoint Number generated by S1-9 is interpreted as heater setpoint in °C or °F.

NONE: Setpoint Number generated by S1-9 has no effects on any setpoints.

Once the jumper is back to NONE position, all the adjusted setpoints will be saved in EEPROM which means that their values will not be changed even after power off.

Terminals

Refer to *Figure 2.2 Typical Wiring Diagram*, for power, heater and RTD field connections.

- **T1** Form C Alarm Dry Contacts: Both NO (terminals 10 and 11) and NC (terminals 12 and 11) are rated 277Vac@0.5A and 30Vdc@0.1A.
- **T2** Alarm Light Output: The output is configured as normally closed. Output is rated 6 Vdc @ 50 mA for an LED type lamp (terminals 8+ and 9-).
- **T3** RTD Input: 3 wire RTD input. Lead resistance compensated. (terminals 5,6,7).
- **T4** Ground Stud.
- **T5** Heater Power Input: 120/277VAC/30A max for TM-1SIH1-xx and 208-240VAC/30A for TM-1DIH2-xx (terminals 1 and 2).
- **T6** Heater Power Output: 30A max (terminals 3 and 4).

Status Lights:

- **L1** HTR ON: Light is on calling for heat.
- **L2** RTD FAIL: Light is on when controller detects open or short RTD inputs.
- **L3** LO TEMP: Light is on when controller detects a low temperature alarm.
- **L4** HI TEMP: Light is on when controller detects a high temperature alarm.
- **L5** AMP FAIL: Light is on when controller detects a current fail alarm.
- **L6** GF: Light is on when controller detects a ground fault trip alarm.
- **L7** PWR ON: Light is on when control power is present.

There are no consumable components contained in any of the models covered in this manual.

There is no cleaning requirements for any of the modules covered in this manual.



Warning - During installation, disconnect power supply.



Warning - The ground fault trip function is intended for equipment protection only and should not be used in place of ground fault protection for personnel protection where this is required.

Figure 2.1 TraceMate Controls and Indicators

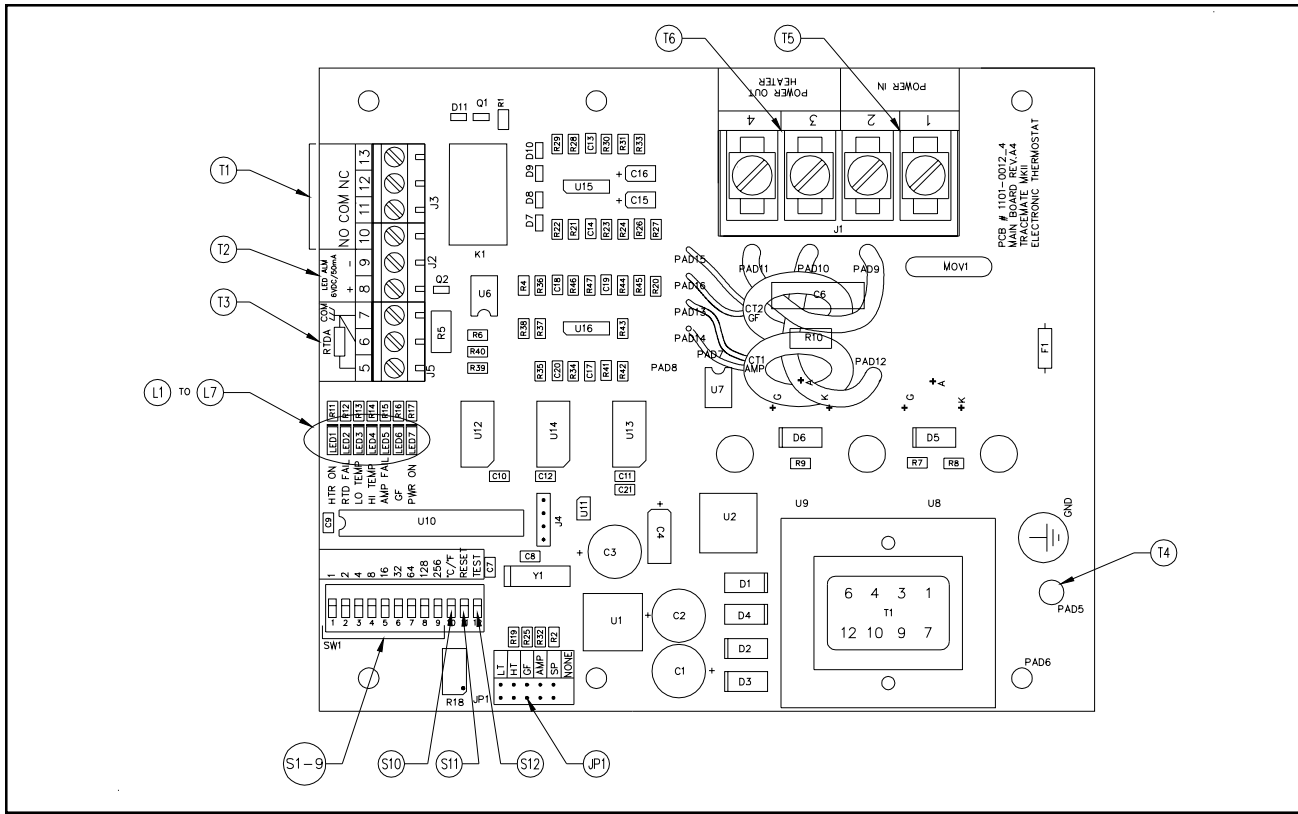
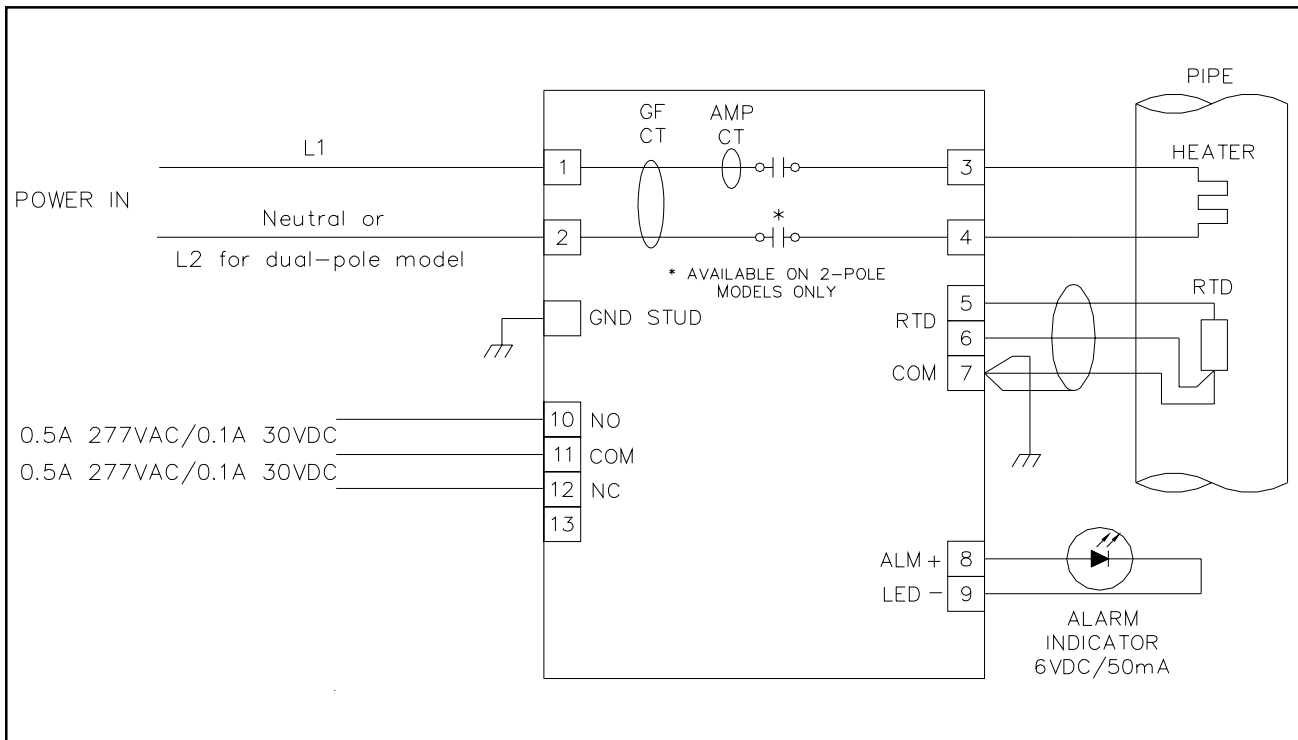

Figure 2.2 Typical Wiring Diagram



Mounting the Controller

Mount the control panel with Unistrut brackets using 3/8" bolts. The Unistrut (or equivalent) mounting allows air circulation to cool the heat-sink. This is important to ensure proper operation of the Tracemate. Mounting dimensions are shown in *Figure 2.5*.

Wire Sizing



Wiring methods should comply with Canadian Electrical or National Electrical Code and local codes. Power and signal wires should not be run in the same conduit system. Wiring should be rated at least 90 °C.

Wire Size (AWG)	Current Load (A)	Max. Ambient Temperature (°C)
6	30	50
8	30	40
10	24	50
12	16	50

Conduit and Cabling

TraceMate comes with one 3/4" and 1/2" conduit knock-outs located on the bottom of the enclosure. Conduit hubs should be NEMA-4X rated, such as T&B H050-0.5 and H075-0.75 or Myers equivalent, to maintain a watertight seal. Unused knockouts should be sealed using NEMA-4X rated seals.

Power Wiring

The power input terminals supply power to both the heat trace and controller. Size power input wires appropriately to the breaker size and maximum ambient operating temperatures. Maximum breaker size is 30A. Connect power wires to input terminals 1 and 2. See *Figure 2.2*.



The supply voltage must be 120VAC (Single-pole) for TM-1SIH1-Ex-RTD, or 277VAC (Single-pole) for TM-1SIH1-Ex-RTD-277V, or 208~240VAC (Dual-pole) for TM-1DIH2-Ex-RTD and rated voltage range of the heat trace cable.

Heater Wiring

Connect heating cable wiring to terminals 3 and 4. See *Figure 2.2*. If the heating cable has a braid, it should be terminated to the ground stud using a ring terminal suitable for #10 stud.



Wiring methods must conform to Class 1, Division II or Class 1, Zone II requirements.

Ground Connection

Connect the controller grounding stud directly to a ground bus using the shortest, practical path. Use a tinned copper, braided bonding cable such as Belden 8660. As a guideline, the ground cables should be minimum 96 strands, number 34 AWG each.

To install the ground connection, remove the outside nut, washer and #8 ring lug provided on the ground stud. Crimp the ground cable to the ring lug and re-assemble onto the ground stud using the washer and nut.

Figure 2.3 Ground Connection

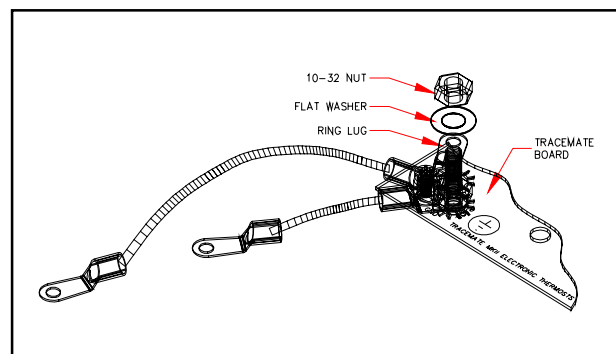

RTD Sensor Wiring

RTD sensors should be 3-wire, 100 ohm, platinum to DIN EN 60751 standard. Mount the RTD element on the pipe, away from the heat trace and 30° to 45° from the bottom of the pipe. The total circuit resistance per conductor from the RTD to the control panel must be less than 10 ohm. Ex-ceeding this resistance will result in a non-linear temperature measurement. Belden cable 8770 or equivalent allows RTDs to be placed up to 1,000 feet from the control panel. Complete all RTD wiring according to *Figure 2.2* Typical Wiring Diagram.



The RTD probe is delicate and should not be bent or used as a tool to puncture insulation.

Figure 2.4 RTD Mounting

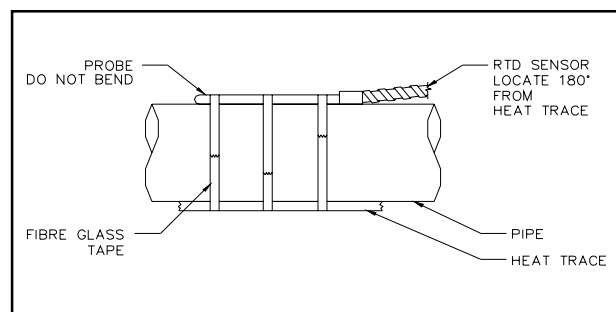

You must install the RTD sensor on the pipe surface or thermal well before the pipe insulation to ensure proper thermal contact. The RTD position should be 180° from the electric heat trace cable which is the coldest spot of the pipe. The RTD sensor may be secured to the pipe by fiberglass tape. If additional wiring is required for the RTD, shielded 3-lead wire sized 18 or 20AWG must be used for the RTD sensor to minimize the effects of noise pickup. A typical RTD installation is shown in *Figure 2.4*.

Alarm Wiring

TraceMate has a form c dry alarm contact and an active alarm output for driving an LED alarm indicator. The alarm LED output is configured to turn on the alarm indicator when there is no alarm. Refer to *Figure 2.2* for contact and alarm output terminals.

The form c dry alarm contact is rated 0.5A 277Vac/0.1A 30Vdc.

The alarm LED output is rated 6Vdc, 50mA. It can drive a 6Vdc LED indicator.

These alarm contact and output are designed as interface to annunciator, PLC, DCS, or panels.



Warning - Explosion Hazard - Substitution of components may impair suitability for Class 1, Division 2 or Class 1, Zone 2.



Warning - Explosion Hazard - Do not disconnect equipment unless power has been switched off or the area is known to be non-hazardous.

Figure 2.5 Enclosure and Mounting Dimensions

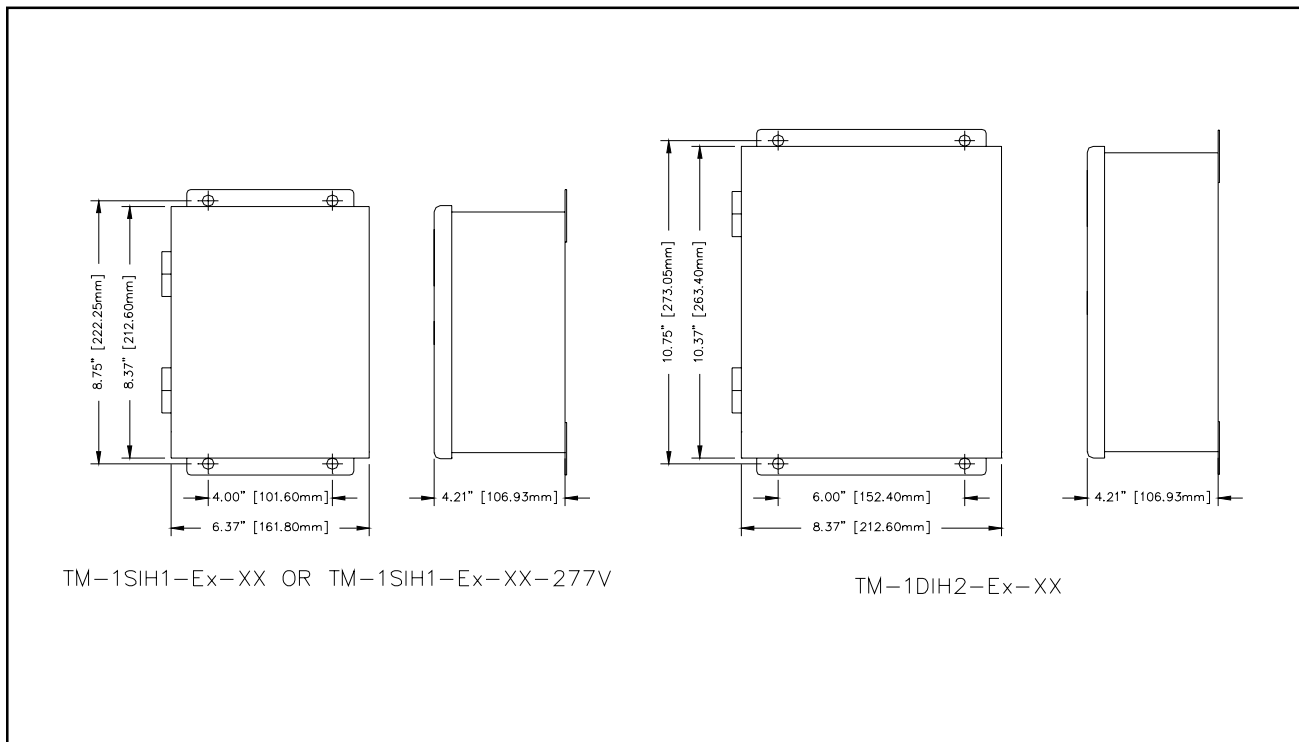

Mechanical Thermostat Replacement

Mount the control unit near the pipe being traced in a location with easy access. Replace the thermostat capillary tube with an RTD mounted on the pipe and connect the existing heater and power wires to the TraceMate as shown in Figure 3.1. A green alarm status light, visible to maintenance personnel, is connected to the TraceMate LED alarm output and should be always on. If the light goes off, the following may have occurred: (1) bulb burnt out (fail-safe indication); (2) no control power available; (3) system fault. Examine the LEDs inside the TraceMate to determine the cause of the alarm.

Advantage of this scheme over mechanical thermostats is: easy setpoint adjustment and early warning of system faults with TraceCheck system exercising every 24 hours and rapid fault diagnosis in the event of a problem.

Figure 3.1 Thermostat Replacement

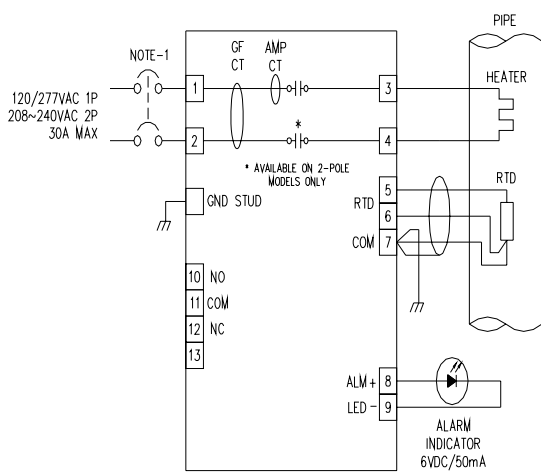

NOTE:
1. USE APPROPRIATE NUMBER OF POLES FOR POWER CONFIGURATION REQUIRED.

Figure 3.2 Alarm Annunciator

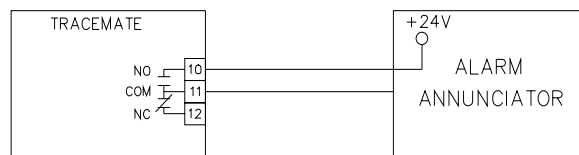

NOTE:
1. IF NO ALARM AND MODULE WITH POWER, CONTACTS 10 & 11 OPEN AND CONTACTS 11 & 12 CLOSED.

Alarm Annunciator

If an alarm annunciator or programmable controller is available, terminal 10, 11 & 12 can be used as a low cost digital interface. These terminals are form C dry contacts. A separate voltage source must be connected across these terminals as shown in Figure 3.2 for the annunciator to sense the alarm logic

Switching Requirements

Two types of TraceMate controllers are available to accommodate different power configuration of electric heat trace. The single-pole switching type is used for phase-to-neutral power feed such as 120 or 277VAC. 208 and 240VAC are both phase-to-phase power feed and will require a dual-pole switching type to ensure both lines are switched off. Not only is this an electrical code requirement, but to ensure both connections to the heater are not hot when the controller is not calling for heat. This is especially important for the ground fault function to operate properly since switching only one line there is a 50% chance that the heater output is properly tripped.

Alarms

When an alarm condition occurs, the form c dry alarm contact reacts and the corresponding alarm LED comes on to indicate the cause of the alarm. Fault diagnosis for these alarms is listed below.

RTD Fail: If the RTD sensor is not connected or shorted, RTD FAIL alarm LED will turn on. Check that the RTD sensor is properly connected. This alarm is not latched and will be reset as soon as the RTD is properly connected. In the event of an RTD failure, the heater output is turned off to prevent a runaway heating situation.

Low Temperature: Once the actual temperature is below the low temperature alarm setpoint, LO TEMP alarm LED will turn on. This will normally indicate that the heater circuit is not providing enough heat to maintain the setpoint. When a system is first turned on this alarm may be activated. It is particularly useful in taking corrective action in freeze protection systems to prevent a burst pipe. This alarm is not latched and will be reset as soon as the alarm condition disappears. **The low temperature alarm will be disabled if its setpoint is set to 511°C.**

High Temperature: Once the actual temperature is above the high temperature alarm setpoint, HI TEMP alarm LED will turn on. This alarm is not latched and will be reset as soon as the alarm condition disappears.

Current Fail: This alarm is activated when the TraceMate control calls for heat and a heater current less than the current fail alarm setpoint flows. Either the continuity of the wiring and heat tracing cable is defective or a very small heater is being switched. In order to detect faults on dormant systems with the TraceCheck feature, which turns on the heaters for several seconds every 24 hours, this alarm is latched. Thus, once the condition is detected, the alarm will remain on until it is reset.

Ground Fault Trip: This alarm is activated when the ground fault current is above the ground fault trip alarm setpoint. A ground fault is a current to ground caused by moisture, corrosion or insulation breakdown. Often the amount of ground fault current is not enough to trip the heater circuit breaker but could result in a serious fire hazard, especially with self-regulating cable.

When a ground fault is detected, the heater will be switched off, even if the control is calling for heat. This eliminates the need for an expensive ground fault circuit breaker. Large ground fault currents will trip the heater circuit breaker, so an intentional time delay is allowed for the breaker to clear high fault currents, which can occur on solidly grounded systems.

Since the heater may be shut off after a ground fault, it is very important that the alarm outputs be used so corrective action can be taken quickly enough to prevent a process shutdown due to the loss of heat to a pipe. Ground fault detection only works with resistance or solidly grounded

systems. If the system is ungrounded, it must be grounded or an artificial ground must be created by means of a zig-zag transformer. Once a ground fault condition is detected, it remains latched until it is reset.

Status Indicators

Power On Indicator: When incoming voltage is applied to the TraceMate, the green PWR ON indicator LED should be on. If this LED is not on, check that the appropriate voltage is present by connecting a meter across terminals 1 and 2. If voltage is present and the LED is off, the controller should be replaced and sent to the factory for service.

Heater On Indicator: Whenever the heater is on, the green HTR ON indicator LED will be on. This is useful for checking correct operation of the control. If the ground fault alarm light or RTD fail alarm light is on, the heater will not switch on even if the actual temperature is below the setpoint.

Alarm Reset

The low/high temperature and RTD fail alarms reset as soon as the condition disappears. The ground fault trip and current fail alarm are latched alarms. A latched alarm will remain even if the alarm condition disappears. To reset the latched alarms, remove incoming power for a few seconds by opening and reclosing the circuit breaker. Provided the alarm conditions are no longer present, the alarms should all be reset when power is re-applied to the TraceMate. It is also possible to reset the latched alarms by momentarily switching S11 towards its **ON** position (refer to Figure 2.1) even if the TraceMate is at control with power applied.

Heater Setpoint and Alarm Setpoints

As stated in chapter 2, five setpoints can be adjusted by properly setting up S1-9 and JP1 (refer to Figure 2.1). S1-9 consists of 9 switches. They are S1, S2, S3, S4, S5, S6, S7, S8 and S9. These 9 switches generate a Setpoint Number in a range of 0-511. The exact value of this Setpoint Number equals the sum of the contributions by each switch. If a switch is in **ON** position, its contribution to the Setpoint Number equals its labelled value on the board. Otherwise, its contribution is zero. For example, if all 9 switches are in **ON** position, Setpoint Number = 1 + 2 + 4 + 8 + 16 + 32 + 64 + 128 + 256 = 511. If only switches S3 and S5 are in **ON** position, Setpoint Number = 0 + 0 + 4 + 0 + 16 + 0 + 0 + 0 = 20.

Depending on the jumper position of JP1, the Setpoint Number generated by S1-9 can be interpreted as either heater setpoint, or low temperature alarm setpoint, or high temperature alarm setpoint, or ground fault trip alarm setpoint, or current fail alarm setpoint.

Heater Setpoint: If the jumper on JP1 is at **SP** position, the Setpoint Number generated by S1-9 is interpreted as the heater setpoint. Whether the setpoint is in °C or °F depends on the position of S10 (refer to Figure 2.1). The factory default value is 20°C.

Low Temperature Alarm Setpoint: If the jumper on JP1 is at **LT** position, the Setpoint Number generated by S1-9 is interpreted as the low temperature alarm setpoint in °C or °F. The factory default value is 5°C. **The low temperature alarm will be disabled if its setpoint is set to 511°C.**

High Temperature Alarm Setpoint: If the jumper on JP1 is at **HT** position, the Setpoint Number generated by S1-9 is interpreted as the high temperature alarm setpoint in °C or °F. The factory default value is 100°C.

Ground Fault Trip Alarm Setpoint: If the jumper on JP1 is at **GF** position, the Setpoint Number generated by S1-9 is interpreted as the ground fault trip alarm setpoint in mA. The factory default value is 30 mA.

Current Fail Alarm Setpoint: If the jumper on JP1 is at **AMP** position, the Setpoint Number generated by S1-9 is divided by 10 and interpreted as the current fail alarm setpoint in A. The factory default value is 0.3 A.

NONE: If the jumper on JP1 is at **NONE** position, the Setpoint Number generated by S1-9 has no effects on any setpoints.

Once the jumper is back to NONE position, all the adjusted setpoints will be saved in EEPROM which means that their values will not be changed even after power off.

Troubleshooting/System Integrity

A major concern in heat tracing is knowing that the control and heater cable are functioning normally. On systems that sit idle for long periods, such as freeze protection, faults usually show up when the system is needed most. Users often perform an annual check on mechanical thermostats to ensure that problems have not developed. This is a tedious task because the controls are often high off the ground in inaccessible areas.

Since the TraceMate control uses an RTD, it can be mounted in a convenient ground level location near other controls for easy access. Indicator lights for HEATER ON and POWER indicate the system status. If the RTD sensor or wiring goes open/short circuit, the NO SENSOR LED comes on indicating a fault. For this condition the actual temperature output indicates a value out of the temperature measurement range, i.e. [-50~500°C] or [-58~932°F]. The control can be forced on or off easily by changing the heater setpoint switches to be above or below the actual process temperature, noting the HEATER ON LED and heater current with a clamp-on ammeter.

Calibration

Although the TraceMate control is constructed with precision components and should give long service without any recalibration necessary, users however may wish to perform periodic calibration checks. When the TraceMate control is first installed, or for periodic maintenance checks, system operation can be verified by adjusting the heater setpoint dip switch 2°C above and below a known temperature on the RTD input to see if the heater turns on and off. For example, if the RTD input temperature is 25°C, setting the heater setpoint to 27°C will force the heater on and conversely a 23°C setpoint will force the heater off.

By substituting a known resistor value for the RTD sensor and looking up the equivalent temperature in tables 5.1 and 5.2, the calibration accuracy of the control can be verified. This can be done in the field without removing the control using a resistance simulator box and a quality digital multimeter.

Disconnect the incoming RTD wires and connect a resistance box. Simulate an RTD temperature using the variable resistor or decade box and set the heater setpoint dip switch 2°C above the simulated temperature. The heater LED should turn on. Setting the heater setpoint dip switch 2°C below the simulated temperature, heater LED should turn off.

Figure 5.1 RTD Simulation

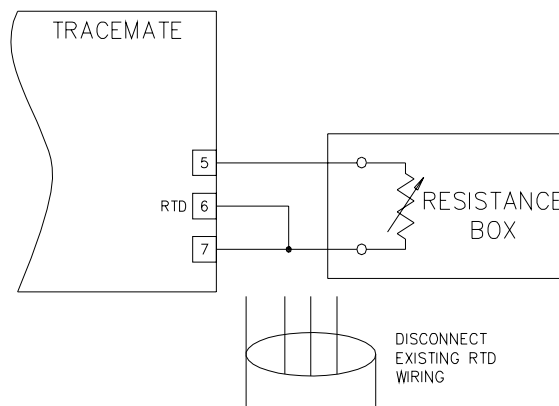

Table 5.1 Resistance versus Temperature in °F (DIN EN 60751 RTD)

F	R (ohms)	F	R (ohms)	F	R (ohms)
-40	84.27	160	127.50	360	169.29
-30	86.47	170	129.62	370	171.34
-20	88.66	180	131.74	380	173.39
-10	90.85	190	133.86	390	175.43
0	93.03	200	135.97	400	177.48
10	95.22	210	138.08	410	179.51
20	97.39	220	140.18	420	181.55
30	99.57	230	142.29	430	183.58
40	101.74	240	144.38	440	185.61
50	103.90	250	146.48	450	187.63
60	106.06	260	148.57	460	189.65
70	108.22	270	150.66	470	191.67
80	110.38	280	152.74	480	193.68
90	112.53	290	154.82	490	195.69
100	114.68	300	156.90	500	197.69
110	116.83	310	158.97		
120	118.97	320	161.04		
130	121.10	330	163.11		
140	123.24	340	165.17		
150	125.37	350	167.23		

Table 5.2 Resistance versus Temperature in °C (DIN EN 60751 RTD)

C	R (ohms)	C	R (ohms)	C	R (ohms)
-40	84.27	80	130.89	200	175.84
-30	88.22	90	134.70	210	179.51
-20	92.16	100	138.50	220	183.17
-10	96.09	110	142.29	230	186.82
0	100.00	120	146.06	240	190.46
10	103.90	130	149.82	250	194.08
20	107.79	140	153.58	260	197.69
30	111.67	150	157.32	270	201.30
40	115.64	160	161.04	280	204.88
50	119.39	170	164.76	290	208.46
60	123.24	180	168.47	300	212.03
70	127.07	190	172.16		

Figure 5.2 Ground Fault Simulation

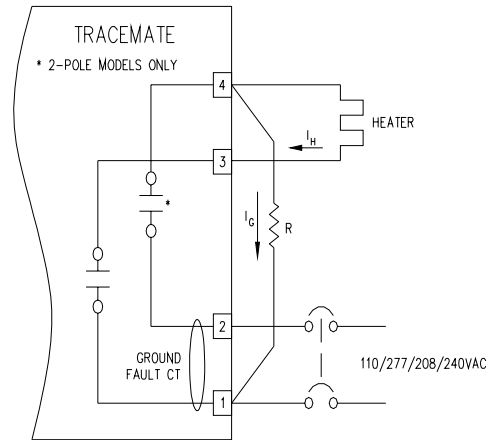

Ground Fault Testing

It is possible to simulate a ground fault by creating a situation where the current from the two heater terminals 1 and 2 is not equal. As shown in figure 5.2, this is done by connecting a resistor across terminals 1 and 4.

Follow these steps to test the ground fault circuit:

1. Turn on incoming power. Set the ground fault trip alarm setpoint to 30mA (default).
2. Turn off incoming power.
3. Connect a resistor between terminals 1 and 4. This allows ground fault current I_g to flow, which will be seen by the ground fault sensor as a ground fault. Size the resistor according to the

Heater Voltage	110	277	240	208	AC Volts
Resistance	2700	6800	6200	5100	Ohms
Wattage	5	15	10	10	Watts
Voltage Rating	250	500	500	500	DC Volts

table to ensure sufficient ground fault current of 30mA ± 25%.

4. Apply power. The ground fault indicator should come on after a short delay. It should not be possible to turn on the heater even if the actual temperature is below the setpoint. The TraceMate acts a ground fault circuit breaker.
5. Turn off incoming power.
6. Remove the ground fault resistor between terminals 1 and 4.
7. Re-apply power. All alarm indicators should be off.

Repairs

In the event of a hardware failure, system operation can be restored quickly by following this procedure:

1. Turn off incoming heater and alarm power.
2. Ensure that all wires are correctly marked for the corresponding terminals.
3. Disconnect all wires to the terminals.
4. Remove any screws holding the TraceMate controller and return it to the factory for repair.
5. Install a replacement TraceMate controller.
6. Reconnect the wires, apply power and follow the testing procedure for a new control.

Warranty

The manufacturer warrants each control that it manufactures to be free from defective material or workmanship for a period of 12 months from date of purchase.

Under this warranty, the obligation of the manufacturer is limited to repairing or replacing the defective control at its option, when returned to the manufacturer's factory with shipping charges prepaid.

If failure has been caused by misuse, incorrect application or alteration of the control, this warranty will be void.

UNLESS SPECIFICALLY PROVIDED FOR IN WRITING IN THIS WARRANTY, EACH CONTROL IS PROVIDED WITHOUT ANY WARRANTY OF ANY KIND EITHER EXPRESSED OR IMPLIED. IN PARTICULAR, WITHOUT LIMITING THE GENERALITY OF THE FOREGOING, THE FOLLOWING IMPLIED WARRANTIES AND CONDITIONS ARE EXPRESSLY DISCLAIMED:

- a). **ANY IMPLIED WARRANTY OR CONDITION THAT THE CONTROL WILL MEET YOUR REQUIREMENTS.**
- b). **ANY IMPLIED WARRANTY OR CONDITION THAT THE OPERATION OF THE CONTROL WILL BE UNINTERRUPTED OR ERROR FREE; AND**
- c). **ANY IMPLIED WARRANTY OR CONDITION OF MERCHANTABILITY OR FITNESS FOR A PARTICULAR PURPOSE.**

The user shall be made aware that if the equipment is used in a manner not specified by the manufacturer, the protection provided by the equipment may be impaired.

**TRACEMATE
ELECTRONIC THERMOSTAT**

Nexttron A Division of Powell 6120 11th Street S.E., Calgary, Alberta, T2H 2L7, Tel: (403) 735-9555, Fax: (403) 735-9559

P/N: 1501-0012_1 TMII 09/16 Printed in Canada