

# ***TRACEMATE II-CTR***

---

**ELECTRONIC THERMOSTAT**

## **OPERATOR'S MANUAL**



---

<b>1 Product Overview .....</b>	<b>1.1</b>
Introduction .....	1.1
Features and Benefits .....	1.1
Conventions .....	1.1
Specifications .....	1.2
<b>2 Installation .....</b>	<b>2.1</b>
Unpacking the Controller .....	2.1
Control Module .....	2.1
Mounting the Controller .....	2.3
Wire Sizing .....	2.3
Conduit and Cabling .....	2.3
Power Wiring .....	2.3
Heater Wiring .....	2.3
Ground Connection .....	2.3
RTD Sensor Wiring .....	2.3
Alarm Wiring .....	2.4
<b>3 Applications .....</b>	<b>3.1</b>
Mechanical Thermostat Replacement .....	3.1
Remote Zone Alarm .....	3.1
Alarm Annunciator .....	3.1
Local Alarm .....	3.1
Switching Requirements .....	3.1
<b>4 Operation .....</b>	<b>4.1</b>
Alarms .....	4.1
Alarm Contacts .....	4.1
Alarm Messages .....	4.1
Alarm Indicators .....	4.1
Status Indicators .....	4.1
Alarm Reset .....	4.2
Heater Setpoint and Alarm Setpoints .....	4.2
<b>5 Testing .....</b>	<b>5.1</b>
Troubleshooting/System Integrity .....	5.1
Calibration .....	5.1
Ground Fault Testing .....	5.2
Repairs .....	5.2
<b>Warranty .....</b>	<b>Back Cover</b>

**Introduction**

The TraceMate II-CTR solid state heat tracing control is an electronic thermostat designed to maintain two seperated heaters at their respective desired setpoint temperatures. It is suitable for use with mineral-insulated, self-regulating or constant-wattage cable in applications such as freeze protection, process control and instrument tracing. The TraceMate II-CTR is intended for indoor or outdoor installation in ordinary or class 1, division 2 hazardous locations.

TraceMate II-CTR offers many advantages over other heat tracing control schemes, which generally use some combination of mechanical thermostats, custom-built panels or programmable controls to provide control, monitoring and alarm functions. Wiring costs are minimized by mounting the control in close proximity to the heat tracing cable and pipe. A NEMA 4 enclosure and wide temperature range electronic components are used to make mounting possible in most locations. Temperature sensing of each heater is achieved by mounting a 100 ohm platinum (DIN 43760) RTD sensor on the pipe. Heater current is controlled by a solid state switch rated 30A. The temperature setpoint and other setpoints are digital for fast non-ambiguous setting over a wide range. Instant system information such as pipe temperatures, heater currents, ground fault currents, and heater on/off & alarm status can be seen on the LCD display mounted on the door of the enclosure. Maximum system reliability is obtained from a comprehensive alarm package which includes LCD display messages and LED indicators for quick fault identification and a ground fault trip to minimize fire hazards.

By combining the control, system monitoring and testing requirements of a heat trace control system into a general purpose control, the TraceMate II-CTR makes it possible to significantly upgrade systems at low installed cost. In addition, it is very flexible in its application to adapt to specific user requirements.

**Conventions**

The following conventions are used in this manual:



Caution: Refer To The Accompanying Documents



Caution: Hot Surface



VDC ( DC Voltage )



VAC ( AC Voltage )



Protective Conductor Terminal

**Features and Benefits**

Requirements	TraceMate II-CRT Features
Temperature Control	<ul style="list-style-type: none"> <li>* 0-511°C/0-511°F setpoint</li> <li>* Non-ambiguous, digital temperature setpoint</li> <li>* 100 ohm platinum RTD sensor</li> <li>* 3-wire, lead resistance compensation</li> </ul>
System Fault Alarms	<ul style="list-style-type: none"> <li>* Breaker left off or tripped</li> <li>* Heater continuity or low current</li> <li>* Ground fault trip</li> <li>* Low temperature</li> <li>* High temperature</li> <li>* Broken sensor</li> </ul>
Early Warning	<ul style="list-style-type: none"> <li>* Tracecheck exercises dormant systems every 24 hours for early warning to prevent shutdowns</li> <li>* LCD display messages and LED indicators show cause of alarms</li> <li>* Separate fail-safe local and remote alarms</li> </ul>
Remote Monitoring	<ul style="list-style-type: none"> <li>* DC or AC alarm output for PLC or remote alarm indication</li> <li>* Form C alarm dry contact output alarm indication</li> <li>* RS232 communication port</li> <li>* 16X1 LCD display</li> </ul>
Hazardous/ Ordinary Area Mounting	<ul style="list-style-type: none"> <li>* CSA approved for ordinary or Class 1, Division 2, Grps A,B,C,D hazardous area</li> <li>* -40° to +50°C operating range</li> <li>* 30 amps @120/208-240/277VAC rating</li> <li>* Weatherproof, Nema-4 enclosure</li> <li>* Easy retrofit replacement for mechanical thermostat</li> </ul>
Low Installed Cost	<ul style="list-style-type: none"> <li>* Competitively priced</li> <li>* Self contained, no control panel to build</li> <li>* Ground fault trip eliminates expensive ground fault circuit breaker</li> <li>* Standard model simplifies spare parts stocking</li> </ul>

**Specifications**

**Temperature Range**

Range: -50°C to 500°C, -58°F to 932°F  
 Hysteresis: ±2°C, ±3.2°F  
 Absolute Accuracy: ±2.5°C, ±4.5°F  
 Repeatability: ±1°C, ±1.8°F  
 RTD: 100 ohm platinum, 3-wire 10 ohms maximum lead resistance

**Heater Switching**

Installation/Overvoltage CAT. III; Pollution Degree 2  
 Configuration TM-2SIH1-RTD: Single-pole  
 TM-2SIH1-RTD-240V: Single-pole  
 TM-2DIH2-RTD-208~240V: Dual-pole  
 TM-2SIH1-RTD-277V: Single-pole  
 Ratings: TM-2SIH1-RTD: 120Vac @ 30A  
 TM-2SIH1-RTD-240V: 240VAC @30A  
 TM-2DIH2-RTD-208~240V: 208~240VAC @30A  
 TM-2SIH1-RTD-277V: 277VAC @30A  
 250 amp 1/2 cycle inrush  
 Line Frequency 50 or 60Hz

**Control Power**

Installation/Overvoltage CAT. III; Pollution Degree 2  
 Power Requirements Control power from heater voltage  
 TM-2SIH1-RTD: 120VAC, 10VA  
 TM-2SIH1-RTD-240V: 240VAC, 10VA  
 TM-2DIH2-RTD-208~240V: 208~240VAC, 10VA  
 TM-2SIH1-RTD-277V: 277VAC, 10VA  
 Protection Control power from heater voltage protected by non-replaceable 2A, time lag, 350 VAC fuse  
 MOV transient protection and RC snubber

**User Interface**

DIP Switch & Jumper Change setpoints, Reset alarm, Heater test  
 Panel Indicators Power on, Heater on, Low temperature alarm, High temperature alarm, Current fail alarm, Ground fault trip alarm, RTD fail alarm  
 LCD Display A comprehensive display of system measurements, setpoint values, heater on/off and alarm status  
 RS232 Port Accessible to PDA, Laptop, PC

**Environment**

Approvals: CSA and FM  
 Class I, Div.2, Groups A,B,C,D  
 Class I, Zone 2, Groups IIC  
 Operating Range: TM-2SIH1-RTD: -40°C to +50°C  
 TM-2SIH1-RTD-240V: -40°C to +50°C  
 TM-2DIH2-RTD-208~240V: -40°C to +50°C  
 TM-2SIH1-RTD-277V: -40°C to +50°C  
 ( LCD display: -20°C to +50°C )  
 Heater current derated  
 Conformal Coating: Boards conformal coated for hostile environments. Altitude: 0-2000m

**User-Definable Options**

Heater Setpoint:  
 Low Temperature Alarm Setpoint:  
 High Temperature Alarm Setpoint: 0°C-511°C, 1°C steps  
 0°F-511°F, 1°F steps  
 Temperature Units: 0°C or °F  
 Current Fail Alarm Setpoint: 0.0A-30.0A, 1 A steps  
 Ground Fault Trip Alarm Setpoint: 0mA-511mA, 1 mA steps

**Enclosure**

Type: Nema-4 steel, painted black  
 Size: TM-2SIH1-RTD: 10"Hx8"Wx4"D  
 TM-2SIH1-RTD-240V: 10"Hx8"Wx4"D  
 TM-2DIH2-RTD-208~240V: 10"Hx8"Wx4"D  
 TM-2SIH1-RTD-277V: 10"Hx8"Wx4"D  
 Features: Quick release latches to open door  
 One 1.125" conduit knockout for power, two 0.843" conduit knocks for RTD wiring, one 0.875" conduit knock for signal wiring, one 0.610" conduit knock for RS232 communication.

**Alarms**

Installation/Overvoltage CAT. II; Pollution Degree 2  
 Low Temperature: Actual temperature < low temperature alarm setpoint  
 High Temperature: Actual temperature > high temperature alarm setpoint  
 Current Fail: Heater current < current fail alarm setpoint  
 Ground Fault Trip: Ground fault current > Ground fault trip alarm setpoint  
 RTD Fail: RTD Open, RTD Short  
 Hardware: No incoming voltage  
 TraceCheck: Current Fail Alarm  
 Configuration: NC Contacts  
 Alarm Output Rating: AC contact: 12-277Vac@ 0.5A max. 50/60 Hz, CAT. II  
 DC contact: 30Vdc/0.1A, 500mW max. Form C dry contact: 12- 277VAC/0.5A, 30VDC/0.1A.

**TraceMate II-CTR  
 Heater Current Rating**

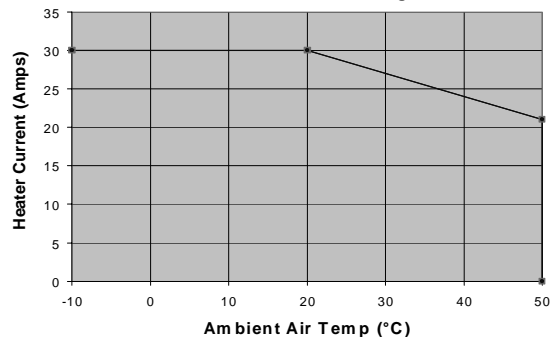

**Unpacking the Controller**

Check the shipping cartons for damage, or other signs of rough handling or abuse. If damaged, notify the shipping carrier at once.

Carefully remove the TraceMate II-CTR from the shipping box.

Inspect face plate for shipping damage and check electronics for loose wiring or damage. Report any damage to the carrier at once.

**Control Module**

See *Figure 2.1 TraceMate II-CTR Controls and Indicator Layout* to locate the following:

Switches and Jumpers

- **S1-9** Setpoint Number:  
S1-9 consists of 9 switches. They are S1, S2, S3, S4, S5, S6, S7, S8 and S9. These 9 switches generate a Setpoint Number in a range of 0-511. The exact value of this Setpoint Number equals the sum of the contributions by each switch. If a switch is in **OFF** position, its contribution is zero. If it is in **ON** position, its contribution equals the value labeled on the board.  
Ex. 1: If all 9 switches are in the **ON** position,  
Setpoint Number = 1+2+4+8+16+32+64+128+256 = 511.  
Ex. 2: If only switches S3 and S5 are in the **ON** position,  
Setpoint Number = 0+0+4+0+16+0+0+0+0 = 20.
- **S10** Temperature Units:  
°C if S10 is on °C side. °F if S10 is on °F side.
- **S11** RESET: Latched “Current fail” or “Ground Fault Trip” alarms of a selected heater are cleared when S11 is switched towards the RESET side momentarily if the alarm conditions no longer exist.
- **S12** Heater selector: Heater 1 is selected if S12 is on HTR1 side. Heater 2 is selected if S12 is on HTR2 side.
- **TEST (JP2)**: Manually forces both heater 1 and heater 2 on when this jumper is shorted. No effect on a heater with an active ground fault trip alarm.
- **JP1** Setpoint Configuration:  
LT: Setpoint Number generated by S1-9 is interpreted as low temperature alarm setpoint in °C or °F for the selected heater.  
HT: Setpoint Number generated by S1-9 is interpreted as high temperature alarm setpoint in °C or °F for the selected heater.  
GF: Setpoint Number generated by S1-9 is interpreted as ground fault trip alarm setpoint in mA for the selected heater.

AMP: Setpoint Number generated by S1-9 is divided by 10 and interpreted as current fail alarm setpoint in A for the selected heater.

SP: Setpoint Number generated by S1-9 is interpreted as heater setpoint in °C or °F for the selected heater.

NONE: Setpoint Number generated by S1-9 has no effects on any setpoints.

Terminals

- **T1** Alarm Contacts: The opto-isolated dc output is rated 30 Vdc @ 0.1 A (terminals 10 and 11) and the triac ac output is rated 277Vac@0.5A (terminals 12 and 13). Contacts are configured as normally closed.
- **T3** Heater 1 RTD Input: 3 wire RTD input. Lead resistance compensated. (terminals 5,6,7).
- **T2** Heater 2 RTD Input: 3 wire RTD input. Lead resistance compensated. (terminals 14,15,16).
- **T4** Form C Alarm Dry Contacts: Both NO (terminals 21 and 22) and NC (terminals 23 and 22) are rated 277Vac@0.5A and 30Vdc@0.1A.
- **T5** Ground Stud.
- **T6** Heater 1 Power Input: 30A max (terminals 1 and 2).
- **T7** Heater 1 Power Output: 30A max (terminals 3 and 4).
- **T8** Heater 2 Power Input: 30A max (terminals 17 and 18).
- **T9** Heater 2 Power Output: 30A max (terminals 19 and 20).

Status Lights:

- **L1** HTR ON: Light is on to when the selected heater is calling for heat.
- **L2** RTD FAIL: Light is on when controller detects open or short on the RTD inputs of the selected heater.
- **L3** LO TEMP: Light is on when controller detects a low temperature alarm on the selected heater.
- **L4** HI TEMP: Light is on when controller detects a high temperature alarm on the selected heater.
- **L5** AMP FAIL: Light is on when controller detects a current fail alarm on the selected heater.
- **L6** GF: Light is on when controller detects a ground fault trip alarm on the selected heater.
- **L7** PWR ON: Light is on when control power is present.

Refer to *Figure 2.2 Typical Wiring Diagram*, for power, heater and RTD field connections.

Figure 2.1 TraceMate II-CTR Controls and Indicators

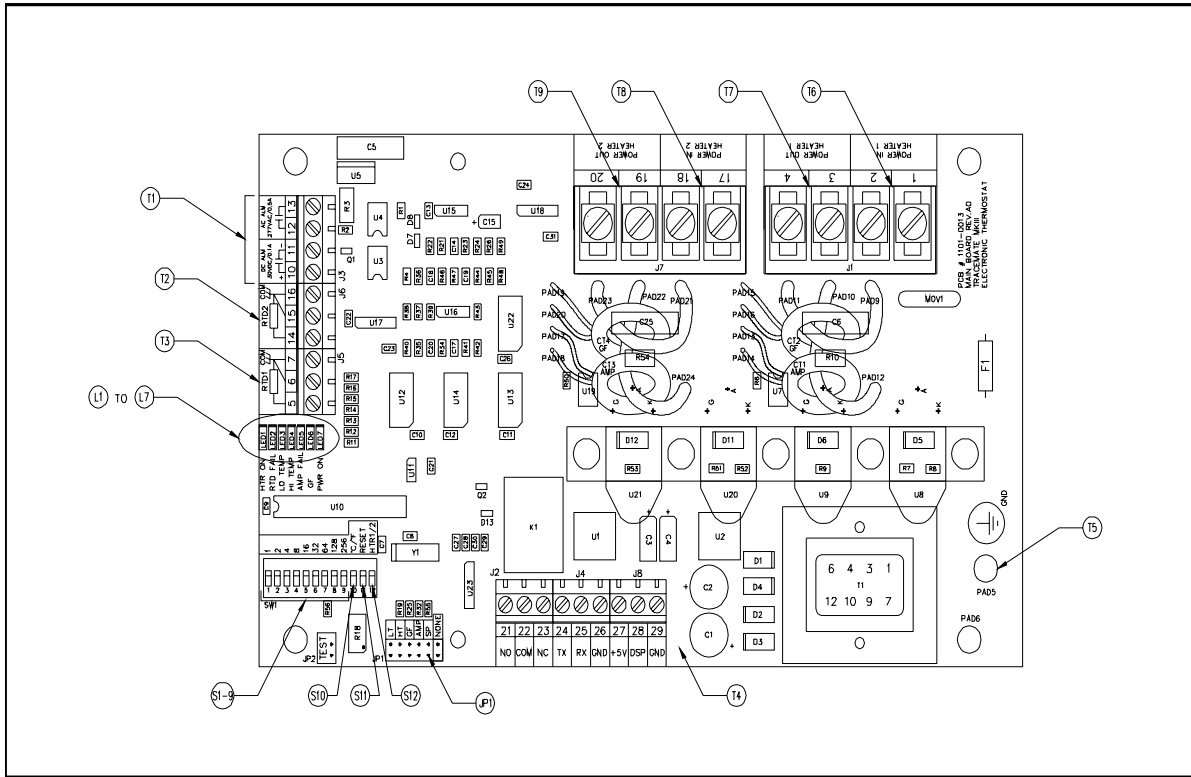
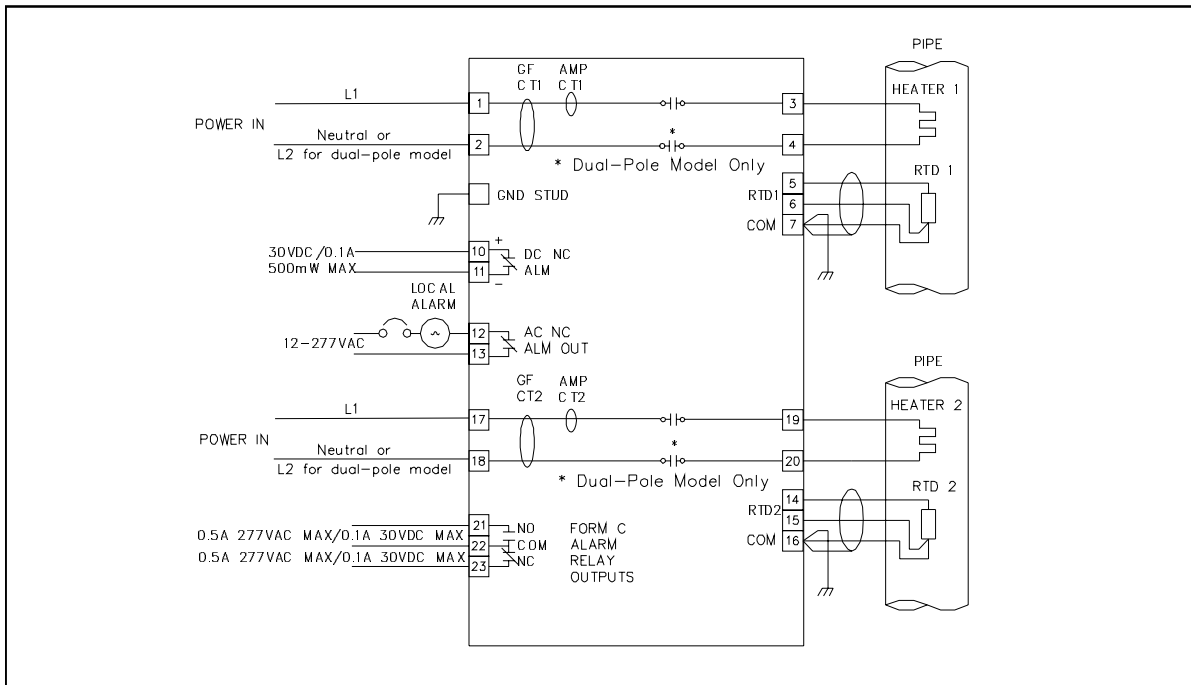

Figure 2.2 Typical Wiring Diagram



**Mounting the Controller**

Mount the control panel with Unistrut brackets using 5/16" bolts. The Unistrut (or equivalent) mounting allows air circulation to cool the heat-sink. This is important to ensure proper operation of the TraceMate II-CTR. Mounting dimensions are shown in *Figure 2.5*.

**Wire Sizing**

**Conduit and Cabling**



**Wiring methods should comply with Canadian Electrical or National Electrical Code and local codes. Power and signal wires should not be run in the same conduit system. Wiring should be rated at least 90 °C, 300 V Min.**

Wire Size (AWG)	Current Load (A)	Max. Ambient Temperature (°C)
6	30	50
8	30	40
10	24	50
12	16	50

TraceMate II-CTR comes with two 0.843" and one 1.125" conduit knockouts located on the bottom of the enclosure. Conduit hubs should be NEMA-4X rated, such as T&B H075-0.75 and H125-1.25 or Myers equivalent, to maintain a watertight seal. Unused knockouts should be sealed using NEMA-4X rated seals.

**Power Wiring**

The power input terminals supply power to both the heat trace and controller. Size the power input wires appropriately to the breaker size and maximum ambient operating temperatures. Maximum breaker size is 30A. Connect power wires to input terminals 1 & 2 for heater 1 and 17 & 18 for heater 2. See *Figure 2.2*. The breaker should be placed as close as possible to the TraceMate II-CTR.



**The supply voltage must be single-pole 120VAC for TM-2SIH1-RTD, single-pole 240VAC for TM-2SIH1-RTD-240V, dual-pole 208~240VAC for TM-2DIH2-RTD-208~240V, and single-pole 277VAC for TM-2SIH1-RTD-277V.**

**Heater Wiring**

Connect heating cable wiring to terminals 3 & 4 for heater 1 and 19 & 20 for heater 2. See *Figure 2.2*. If the heating cable has a braid, it should be terminated to the ground stud using a ring terminal suitable for #10 stud.



**Wiring methods must conform to Class 1, Division II or Class 1, Zone II requirements.**

**Ground Connection**

Connect the controller grounding stud directly to a ground bus using the shortest, practical path. Use a tinned copper, braided bonding cable such as Belden 8660. As a guideline, the ground cables should be minimum 96 strands, number 34 AWG each.

To install the ground connection, remove the outside nut, washer and #8 ring lug provided on the ground stud. Crimp the ground cable onto the ring lug and re-assemble onto the ground stud using the washer and nut.

*Figure 2.3* Ground Connection

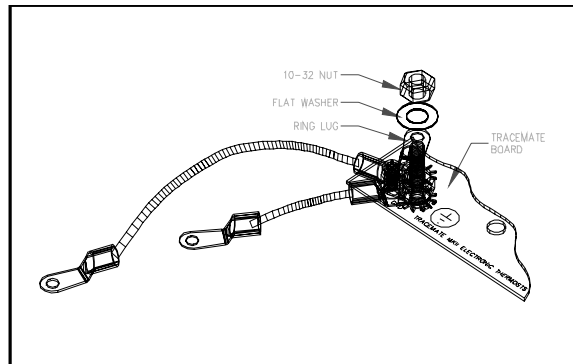

**RTD Sensor Wiring**

RTD sensors should be 3-wire, 100 ohm, platinum to DIN standard 43760. Mount the RTD element on the pipe, away from the heat trace and 180° from the bottom of the pipe. The total circuit resistance per conductor from the RTD to the control panel must be less than 10 ohm. Exceeding this resistance will result in a non-linear temperature measurement. Beldon cable 8770 or equivalent allows RTDs to be placed up to 1,000 feet from the control panel. Complete all RTD wiring according to *Figure 2.2 Typical Wiring Diagram*.



**The RTD probe is delicate and should not be bent or used as a tool to puncture insulation.**

*Figure 2.4* RTD Mounting

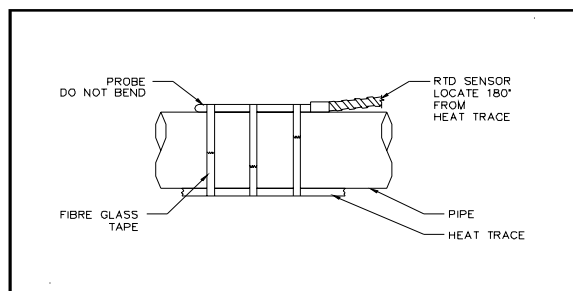

You must install the RTD sensor on the pipe surface or thermal well before the pipe insulation to ensure proper thermal contact. The RTD position should be 180° from the electric heat trace cable which is the coldest spot of the pipe. The RTD sensor may be secured to the pipe by fiber-glass tape. If additional wiring is required for the RTD, shielded 3-lead wire sized 18 or 20AWG must be used for the RTD sensor to minimize the effects of noise pickup. A typical RTD installation is shown in *Figure 2.4*.

**Alarm Wiring**

TraceMate II-CTR has two passive alarm contacts. Both of them are configured as normally closed contacts. Also, TraceMate II-CTR has a Form C alarm dry contact. Refer to *Figure 2.2* for alarm output terminals. The AC triac alarm output is rated 12-277Vac, 0.5A. The DC alarm output is an opto-isolated transition output rated 30Vdc/100mA, 500mW max. The Form C dry alarm contact is rated 0.5A 277Vac/0.1A 30Vdc max. These alarm outputs are designed to interface to annunciator, panels, PLC or DCS.



**Warning - Explosion Hazard - Substitution of components may impair suitability for Class 1, Division 2 or Class 1, Zone 2.**



**Warning - Explosion Hazard - Do not disconnect equipment unless power has been switched off or the area is known to be non-hazardous.**

There are no consumable components contained in any of the models covered in this manual.

There is no cleaning requirements for any of the modules covered in this manual.



**Warning - During installation, disconnect power supply.**



**Warning - The ground fault trip function is intended for equipment protection only and should not be used in place of ground fault protection for personnel protection where this is required.**



**Warning - The operator of this instrument is advised that if the instrument is used in a manner not specified in this manual, the protection provided by the equipment may be impaired.**

*Figure 2.5* Enclosure and Mounting Dimensions

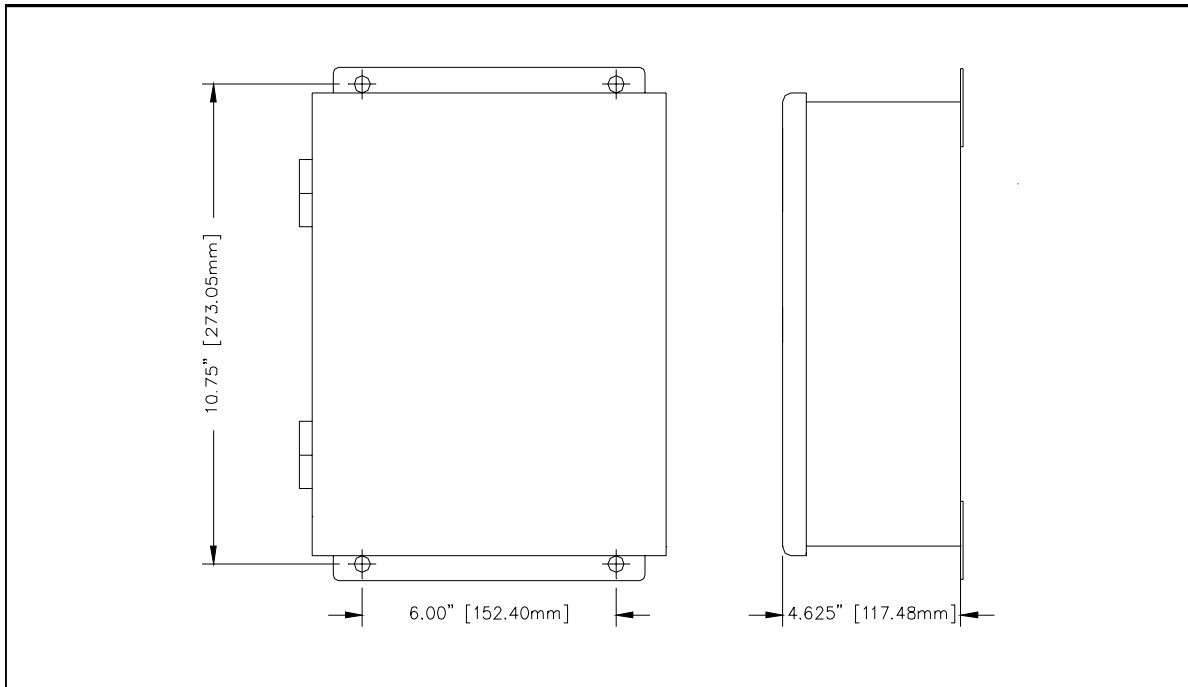

**Mechanical Thermostat Replacement**

Mount the control unit near the pipe being traced in a location with easy access. Replace the thermostat capillary tube with an RTD mounted on the pipe and connect the existing heater and power wires to the TraceMate II-CTR as shown in Figure 3.1. A 16x1 LCD display is mounted on the door of TraceMate II-CTR. Instant system measurements such as pipe temperatures, heater currents, ground fault currents, and heater on/off status can be seen on the display. Also, the alarm status of each heater and their causes are shown on the display. If control power is not available, the LCD display will go off.

Advantage of this scheme over mechanical thermostats is: easy setpoint adjustment, ground fault current protection, early warning of system faults with TraceCheck system exercising every 24 hours and rapid fault diagnosis in the event of a problem.

Figure 3.1 Thermostat Replacement

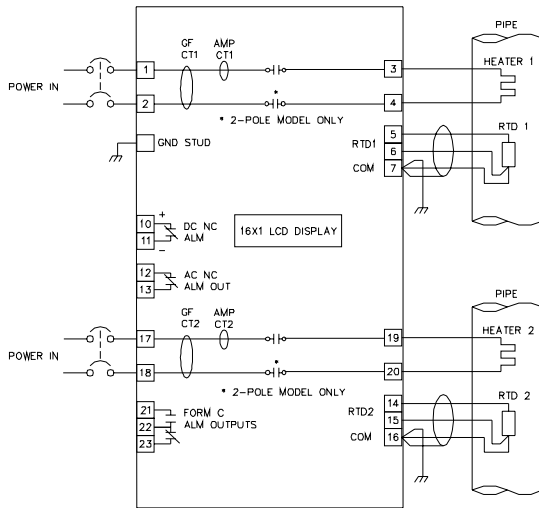

**Remote Zone Alarm**

If a remote alarm is required, a number of TraceMate II-CTR control alarms can be connected to give a remote zone alarm indication in a control room as shown in Figure 3.2. Once the alarm goes on, maintenance personnel can be dispatched to the area. The heat trace point with a problem can be identified by the alarm messages on the LCD display. For a fast diagnosis and repair, the alarm message on the display and the status LED indicators in the TraceMate II-CTR identify the exact nature of the problem. This simple connection minimizes control room panel space, allowing a few LCD displays and indicators to cover a complete plant.

**Alarm Annunciator**

If an alarm annunciator or programmable controller is available, terminal 21, 22 & 23 can be used as a low cost

Figure 3.2 Alarm Wiring

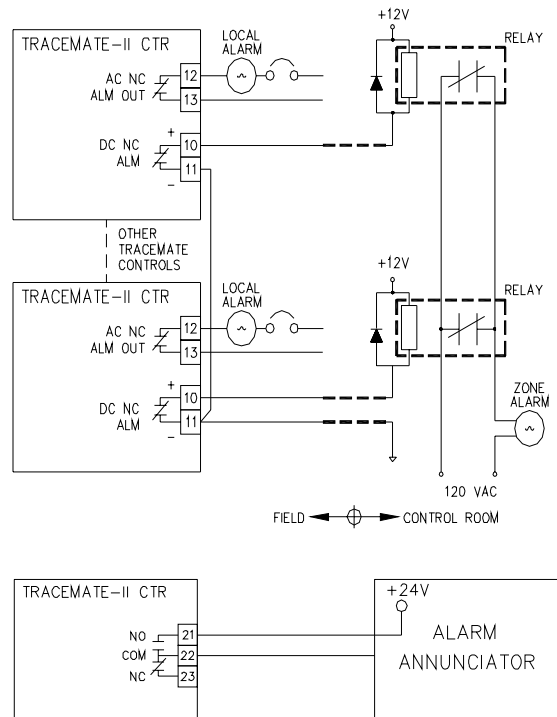

- NOTE:
- CONTACTS 10 & 11 CLOSED IF NO ALARM.
  - CONTACTS 21 & 22 OPEN IF NO ALARM.
  - CONTACTS 12 & 13 CLOSED IF NO ALARM.

digital interface. These terminals are form C dry contacts. A separate voltage source must be connected across these terminals as shown in Figure 3.2 for the annunciator to sense the alarm logic.

**Local Alarm**

A local visual alarm indicator can also be connected to the isolated AC alarm output terminals 12 and 13 as shown in Figure 3.2.

**Switching Requirements**

Four different TraceMate II-CTR models are available to accommodate different power rating of electric heat trace. TM-2SIH1-RTD is rated single-pole 120VAC@30A; TM-2SIH1-RTD-240V is rated single-pole 240VAC@30A; TM-2DIH2-RTD-208~240V is rated dual-pole 208~240VAC@30A; TM-2SIH1-RTD-277V is rated single-pole 277VAC@30A. Refer to Figure 2.2 Typical Wiring Diagram for power and heater wiring.

## Alarms

There are totally 5 types of alarm in TraceMate II-CTR. They are listed below.

**RTD Fail:** If the RTD sensor is not connected or shorted, an RTD Fail alarm occurs. Check that the RTD sensor is properly connected. This alarm is not latched and will be reset as soon as the RTD is properly connected. In the event of an RTD failure, the heater output is turned off to prevent a runaway heating situation.

**Low Temperature:** Once the actual temperature is below the low temperature alarm setpoint, a Low Temperature alarm occurs. This will normally indicate that the heater circuit is not providing enough heat to maintain the setpoint. When a system is first turned on this alarm may be activated. It is particularly useful in taking corrective action in freeze protection systems to prevent a burst pipe. This alarm is not latched and will be reset as soon as the alarm condition disappears.

**High Temperature:** Once the actual temperature is above the high temperature alarm setpoint, High Temperature alarm occurs. This alarm is not latched and will be reset as soon as the alarm condition disappears.

**Current Fail:** This alarm is activated when a heater in TraceMate II-CTR calls for heat but the actual current is less than the current fail alarm setpoint. Either the continuity of the wiring and heat tracing cable is defective or a very small heater is being switched. In order to detect faults on dormant systems with the TraceCheck feature, which turns on the heaters for 20 seconds every 24 hours, this alarm is latched. Thus, once the condition is detected, the alarm will remain on until reset.

**Ground Fault Trip:** This alarm is activated when the ground fault current is above the ground fault trip alarm setpoint. A ground fault is a current to ground caused by moisture, corrosion or insulation breakdown. Often the amount of ground fault current is not enough to trip the heater circuit breaker but could result in a serious fire hazard, especially with self-regulating cable. When a ground fault is detected, the heater will be switched off, even if the control is calling for heat. This eliminates the need for an expensive ground fault circuit breaker. Large ground fault currents will trip the heater circuit breaker, so an intentional time delay is allowed for the breaker to clear high fault currents, which can occur on solidly grounded systems.

Since a heater may be shut off after a ground fault, it is very important that the alarm outputs be used so corrective action can be taken quickly enough to prevent a process shutdown due to the loss of heat to a pipe. Ground fault detection only works with resistance or solidly grounded systems. If the system is ungrounded, it must be grounded or an artificial ground must be created by means of a zip-zag transformer. Once a ground fault condition is detected, it remains latched until it is reset.

## Alarm Contacts

When an alarm occurs, the two alarm contacts are activated. Since both these contacts are configured as normally closed, the impedances across terminal 10 & 11 and terminal 12 & 13 both increase significantly. The From C alarm dry contact reacts to the alarm/no power situation like this: Terminal 21 & 22 become closed and terminal 22 & 23 become open.

## Alarm Messages

When an alarm condition occurs on a particular heater, a corresponding alarm message will be shown on the LCD to provide a fast fault diagnosis.

For an RTD fail alarm on heater x, the alarm message is “**RTD Fail on HTRx**”.

For a low temperature alarm on heater x, the alarm message is “**LT Alarm on HTRx**”.

For a high temperature alarm on heater x, the alarm message is “**HT Alarm on HTRx**”.

For a current fail alarm on heater x, the alarm message is “**AMP Fail on HTRx**”.

For a ground fault trip alarm on heater x, the alarm message is “**GF Alarm on HTRx**”.

## Alarm Indicators

There are 5 alarm indicators on the control board of the TraceMate II-CTR. They are used to indicate the alarm conditions for a particular heater selected by S12, refer to Figure 2.1.

**RTD Fail Indicator:** When an RTD Fail alarm condition occurs on the selected heater, the red RTD FAIL indicator LED will be on.

**Low Temperature Indicator:** When a low temperature alarm condition occurs on the selected heater, the red LO TEMP indicator LED will be on.

**High Temperature Indicator:** When a high temperature alarm condition occurs on the selected heater, the red HT TEMP indicator LED will be on.

**Current Fail Indicator:** When a current fail alarm condition occurs on the selected heater, the red AMP FAIL indicator LED will be on.

**Ground Fault Trip Indicator:** When a ground fault trip alarm condition occurs on the selected heater, the red GF indicator LED will be on.

## Status Indicators

**Power On Indicator:** The control power for the TraceMate II-CTR comes from heater 1's power inputs (terminal 1 & 2). When the control power is applied to the TraceMate II-CTR, the green PWR ON indicator LED should be on. If this LED is not on, check that the appropriate voltage is present by connecting a meter across terminals 1 and 2. If voltage is present and the LED is off, the control board should be replaced and sent

to the factory for service.

**Heater On Indicator:** Whenever a heater is on, the green HTR ON indicator LED will be on if the heater is selected by S12, refer to Figure 2.1. This is useful for checking correct operation of the control. If the ground fault alarm light or RTD fail alarm light is on, the heater will not switch on even if the actual temperature is below the setpoint.

### Alarm Reset

The low/high temperature and RTD fail alarms reset as soon as the condition disappears. The ground fault trip and current fail alarm are latched alarms. A latched alarm will remain even if the alarm condition disappears. To reset the latched alarms, remove heater 1's incoming power for a few seconds by opening and reclosing the circuit breaker. Provided the alarm conditions are no longer present, the alarms should all be reset when power is re-applied. It is also possible to use S11 to reset the latched alarms on the selected heater. To do that, first use S12 to select the heater, and then momentarily switch S11 towards its **ON** position ( refer to Figure 2.1 ).

### Heater Setpoint and Alarm Setpoints

As stated in chapter 2, five setpoints can be adjusted by properly setting up S1-9, S10, S12 and JP1 ( refer to Figure 2.1 ). S1-9 consists of 9 switches. They are S1, S2, S3, S4, S5, S6, S7, S8 and S9. These 9 switches generate a Setpoint Number in a range of 0-511. The exact value of this Setpoint Number equals the sum of the contributions from each switch. If a switch is in **ON** position, its contribution to the Setpoint Number equals its labelled value on the board. Otherwise, its contribution is zero. For example, if all 9 switches are all in **ON** position, Setpoint Number =  $1 + 2 + 4 + 8 + 16 + 32 + 64 + 128 + 256 = 511$ . If only switches S3 and S5 are in **ON** position, Setpoint Number =  $0 + 0 + 4 + 0 + 16 + 0 + 0 + 0 + 0 = 20$ .

Whether the Setpoint Number is for heater 1 or heater 2 depends on the position of switch S12.

Depending on the jumper position of JP1, the Setpoint Number generated by S1-9 can be interpreted as either heater setpoint, or low temperature alarm setpoint, or high temperature alarm setpoint, or ground fault trip alarm setpoint, or current fail alarm setpoint.

**Heater Setpoint:** If the jumper is at SP position, the Setpoint Number is interpreted as the heater setpoint for the selected heater. Whether the setpoint is in °C or °F depends on the position of S10 ( refer to Figure 2.1 ). The factory default value is 20°C.

**Low Temperature Alarm Setpoint:** If the jumper is at LT position, the Setpoint Number is interpreted as the low temperature alarm setpoint in °C or °F for the selected heater. The factory default value is 5°C.

**High Temperature Alarm Setpoint:** If the jumper is at HT position, the Setpoint Number is interpreted as the high temperature alarm setpoint in °C or °F for the selected heater. The factory default value is 100°C.

**Ground Fault Trip Alarm Setpoint:** If the jumper at GF position, the Setpoint Number is interpreted as the ground fault trip alarm setpoint in mA for the selected heater. The factory default value is 30 mA.

**Current Fail Alarm Setpoint:** If the jumper is at AMP position, the Setpoint Number divided by 10 is interpreted as the current fail alarm setpoint in A for the selected heater. The factory default value is 0.3 A.

**NONE:** If the jumper is at NONE position, the Setpoint Number has no meaning to any heater.

Once the jumper is at NONE position, all the adjusted setpoints will be saved in EEPROM which means that their values will not be changed even after power off.

It would be very helpful to use the setpoint messages on the LCD display to verify if the desired setpoint has been properly set or not.

1. For heater x's setpoint, the message is "**SPx = ---°C**", or "**SPx = ---°F**". Where, x refers to the heater number. It could be either 1 or 2. This message would be the sole message on the display if JP1 is at SP position.
2. For heater x's low temperature alarm setpoint, the message is "**LT SPx = ---°C**", or "**LT SPx = ---°F**". This message would be the sole message on the display if JP1 is at LT position.
3. For heater x's high temperature alarm setpoint, the message is "**HT SPx = ---°C**", or "**HT SPx = ---°F**". This message would be the sole message on the display if JP1 is at HT position.
4. For heater x's current fail alarm setpoint, the message is "**AMP SPx = --- A**". This message would be the sole message on the display if JP1 is at AMP position.
5. For heater x's ground fault trip alarm setpoint, the message is "**GF SPx = --- mA**". This message would be the sole message on the display if JP1 is at GF position.
6. If JP1 is at NONE position, the messages such as system measurements, setpoint values, heater on/off and alarm status will be continuously cycled through on the LCD display.

**Troubleshooting/System Integrity**

A major concern in heat tracing is knowing that the control and heater cable are functioning normally. On systems that sit idle for long periods, such as freeze protection, faults usually show up when the system is needed most. Users often perform an annual check on mechanical thermostats to ensure that problems have not developed. This is a tedious task because the controls are often high off the ground in inaccessible areas. Since the TraceMate II-CTR control uses RTDs, it can be mounted in a convenient ground level location near other controls for easy access. Indicator lights for HEATER ON and POWER indicate the system status. If an RTD sensor or wiring goes open/short circuit, an RTD Fail on HTRx alarm message appears on the LCD display and the RTD FAIL LED comes on indicating a fault. For this condition the actual temperature output indicates a value out of the temperature measurement range, i.e. [-50°C-500°C] or [-58°F-932°F].

The control can be forced on or off easily by changing the heater setpoint switches to be above or below the actual process temperature, noting the HTR ON LED and heater current with a clamp-on ammeter.

**Calibration**

Although the TraceMate II-CTR control is constructed with precision components and should give long service without any recalibration necessary, users however may wish to perform periodic calibration checks. When the TraceMate II-CTR control is first installed, or for periodic maintenance checks, system operation can be verified by adjusting the heater setpoint 2°C above and below a known temperature on the RTD input to see if the heater turns on and off. For example, if the RTD input temperature is 25°C, setting the heater setpoint to 27°C will force the heater on and conversely a 23°C setpoint will force the heater off.

By substituting a known resistor value for the RTD sensor and looking up the equivalent temperature in tables 5.1 and 5.2, the calibration accuracy of the control can be verified. This can be done in the field without removing the control using a resistance simulator box and a quality digital multimeter.

Disconnect the incoming RTD wires and connect a resistance box. Simulate an RTD temperature using the variable resistor or decade box and set the heater setpoint 2°C above the simulated temperature. The HTR ON LED should turn on. Setting the heater setpoint 2°C below the simulated temperature, the LED should turn off.

FIGURE 5.1 RTD SIMULATION

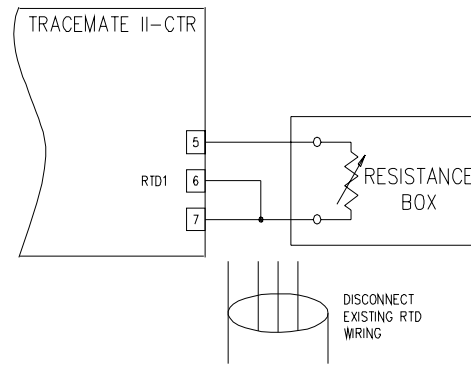

Table 5.1 Resistance versus Temperature in °F (DIN 43760 RTD)

°F	R (ohms)	°F	R (ohms)	°F	R (ohms)
-40	84.27	160	127.50	360	169.29
-30	86.47	170	129.62	370	171.34
-20	88.66	180	131.74	380	173.39
-10	90.85	190	133.86	390	175.43
0	93.03	200	135.97	400	177.48
10	95.22	210	138.08	410	179.51
20	97.39	220	140.18	420	181.55
30	99.57	230	142.29	430	183.58
40	101.74	240	144.38	440	185.61
50	103.90	250	146.48	450	187.63
60	106.06	260	148.57	460	189.65
70	108.22	270	150.66	470	191.67
80	110.38	280	152.74	480	193.68
90	112.53	290	154.82	490	195.69
100	114.68	300	156.90	500	197.69
110	116.83	310	158.97		
120	118.97	320	161.04		
130	121.10	330	163.11		
140	123.24	340	165.17		
150	125.37	350	167.23		

Table 5.2 Resistance versus Temperature in °C (DIN 43760 RTD)

°C	R (ohms)	°C	R (ohms)	°C	R (ohms)
-40	84.27	80	130.89	200	175.84
-30	88.22	90	134.70	210	179.51
-20	92.16	100	138.50	220	183.17
-10	96.09	110	142.29	230	186.82
0	100.00	120	146.06	240	190.46
10	103.90	130	149.82	250	194.08
20	107.79	140	153.58	260	197.69
30	111.67	150	157.32	270	201.30
40	115.64	160	161.04	280	204.88
50	119.39	170	164.76	290	208.46
60	123.24	180	168.47	300	212.03
70	127.07	190	172.16		

**Ground Fault Testing**

It is possible to simulate a ground fault on heater 1 by creating a situation where the current from the heater 1's power input terminals, terminal 1 and 2, is not equal. As shown in figure 5.2, this is done by connecting a resistor across terminals 1 and 4.

Follow these steps to test the ground fault circuit:

1. Turn on incoming power. Set the ground fault trip alarm setpoint to 30mA ( default ).
2. Turn off incoming power.
3. Connect a resistor between terminals 1 and 4. This allows ground fault current  $I_G$  to flow, which will be seen by the ground fault sensor as a ground fault. Size the resistor according to the table to ensure sufficient ground fault current of  $30mA \pm 25%$ .

Heater Voltage	110	240	277	AC Volts
Resistance	2700	6200	6800	Ohms
Wattage	5	10	15	Watts
Voltage Rating	250	500	500	DC Volts

4. Apply power. The ground fault indicator should come on after a short delay. It should not be possible to turn on the heater even if the actual temperature is below the setpoint. The TraceMate II-CTR acts a ground fault circuit breaker.
5. Turn off incoming power.
6. Remove the ground fault resistor between terminals 1 and 4.
7. Re-apply power. All alarm indicators should be off.

FIGURE 5.2 GROUND FAULT SIMULATION

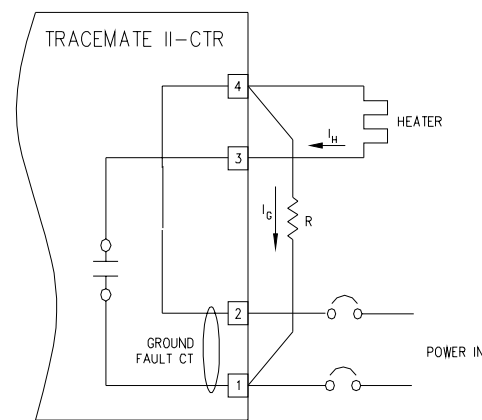

**Repairs**

In the event of a hardware failure, system operation can be restored quickly by following this procedure:

1. Turn off incoming heater and alarm power.
2. Ensure that all wires are correctly marked for the corresponding terminals.
3. Disconnect all wires to the terminals.
4. Remove any screws holding the TraceMate II-CTR controller and return it to the factory for repair.
5. Install a replacement TraceMate II-CTR control module. A replacement module, without the enclosure, can be ordered as a spare part. See the order codes.
6. Reconnect the wires, apply power and follow the testing procedure for a new control.

### Warranty

The manufacturer warrants each control that it manufactures to be free from defective material or workmanship for a period of 12 months from date of purchase.

Under this warranty, the obligation of the manufacturer is limited to repairing or replacing the defective control at its option, when returned to the manufacturer's factory with shipping charges prepaid.

If failure has been caused by misuse, incorrect application or alteration of the control, this warranty will be void.

**UNLESS SPECIFICALLY PROVIDED FOR IN WRITING IN THIS WARRANTY, EACH CONTROL IS PROVIDED WITHOUT ANY WARRANTY OF ANY KIND EITHER EXPRESSED OR IMPLIED. IN PARTICULAR, WITHOUT LIMITING THE GENERALITY OF THE FOREGOING, THE FOLLOWING IMPLIED WARRANTIES AND CONDITIONS ARE EXPRESSLY DISCLAIMED:**

- a). ANY IMPLIED WARRANTY OR CONDITION THAT THE CONTROL WILL MEET YOUR REQUIREMENTS.
- b). ANY IMPLIED WARRANTY OR CONDITION THAT THE OPERATION OF THE CONTROL WILL BE UNINTERRUPTED OR ERROR FREE; AND
- c). ANY IMPLIED WARRANTY OR CONDITION OF MERCHANTABILITY OR FITNESS FOR A PARTICULAR PURPOSE.

The user shall be made aware that if the equipment is used in a manner not specified by the manufacturer, the protection provided by the equipment may be impaired.

**TRACEMATE II-CRT  
ELECTRONIC THERMOSTAT**

Nexttron Corporation 6120 11<sup>th</sup> Street S.E., Calgary, Alberta, T2H 2L7, Tel:(403) 735-9555, Fax: (403) 735-9559

---

P/N: 1501-0014 TM II-CTR 08/07 Printed in Canada