

MASTERTRACE NETWORK

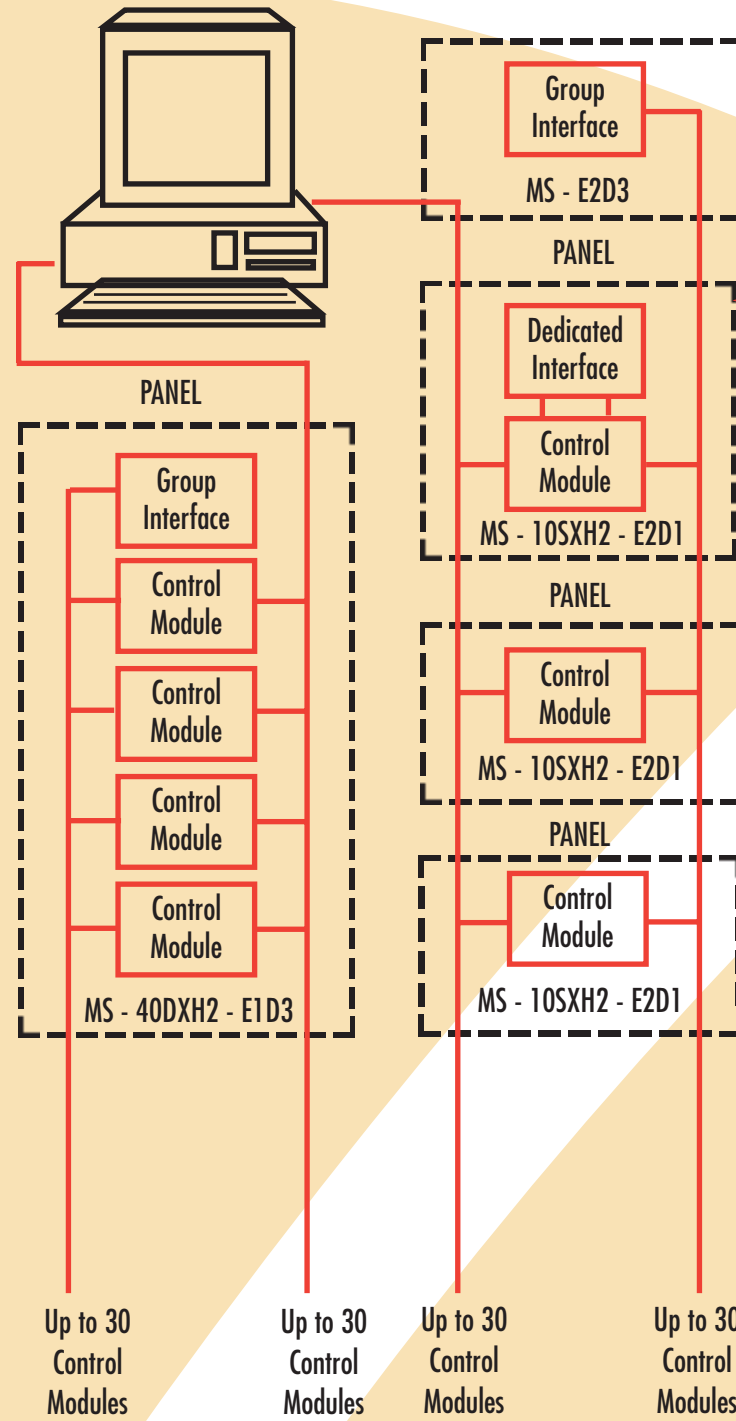

TYPICAL MASTERTRACE PANELS

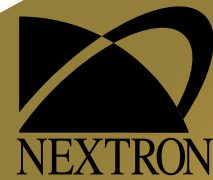
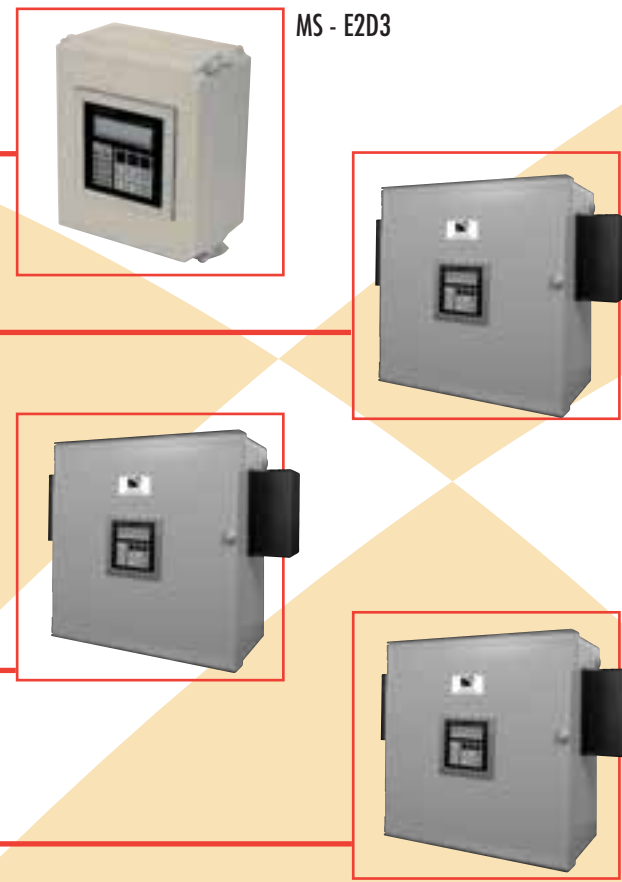

MASTERTRACE

HEAT TRACE CONTROLLERS

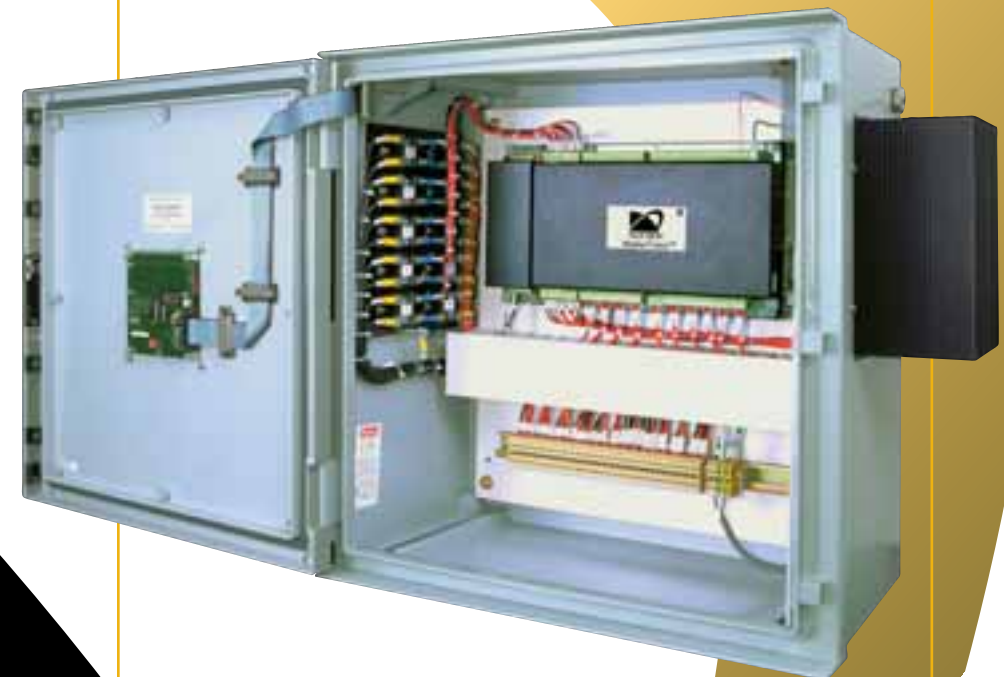

FEATURES	BENEFITS
Built in GFI	Eliminates need for expensive ground fault breaker.
TraceCheck Early Warning	Alerts operators to problems even when the circuit is not in use.
Modbus® Protocol	Allows easy interfacing with our MC-100* software or PLC and DCS systems.
Alarm Outputs	Common Alarm alerts users to problems.
Centralized Interfacing	No need to move around the plant. All variables are monitored at a single location.
Statistics Monitoring	Save energy by monitoring peak demand times.
Staggerstart	Limits initial start up power.
Proportional Control	Provides tight process temperature control.

- Available in One, Two, Five and Ten Point Modules
- Easy to read Interface Display for all Heat Tracing Circuits
- 16-Character Alphanumeric Display, Field Mounted or Remote Mounted
- Modbus® Communications
- RS 485 Serial Port Connections
- TraceCheck™ Early Warning System
- Power Limiting
- Load Shedding
- Solid State or Mechanical Switching Units
- Plant Wide Windows Based Monitoring Software
- Links to PLC's or DCS
- Custom Engineered Panel Design
- Custom Engineered Software Design

Manufactured by:
NEXTRON LIMITED A Powell Canada Company
 #14, 6120-11 Street S.E.
 Calgary, AB T2H 2L7
 (403) 735-9555 • Fax (403) 735-9559 • Toll Free 1-866-639-2875
 E-mail: sales@nextron.ca



Distributed By:

The manufacturer believes the information provided by the manufacturer and describing the manufacturer's products is correct. However, users of the manufacturer's information accept all risk of any damages or loss whatsoever that a user may suffer from using the manufacturer's information and the manufacturer's products (including, without limitation, defects in the manufacturer's products), whether the action is based in contract or not (including negligence). Therefore, users should evaluate the product and the suitability of the product for the user's application.
 WITHOUT LIMITING THE ABOVE, IN NO EVENT SHALL THE MANUFACTURER BE LIABLE FOR SPECIAL, INDIRECT, INCIDENTAL, CONSEQUENTIAL, EXEMPLARY OR PUNITIVE DAMAGES FOR ANY BREACH OR OUR OBLIGATIONS OR WARRANTIES OF ANY SORT, EXPRESS OR IMPLIED, RESULTING FROM THE USER'S USE OF THE MANUFACTURER'S INFORMATION.
 The user hereby agrees to save and hold the manufacturer harmless from any loss, damage, or product liability claim of any sort resulting from the user's use of information or the manufacturer's products.



MASTERTRACE HEAT TRACING SYSTEM

MasterTrace Heat Tracing Systems are designed to be the very best in electrical heat trace control and monitoring for industrial applications. Custom engineered control panels designed to your specific requirements incorporate the unequalled quality and reliability of Nextron Limited's MasterTrace control modules.

Configurations built to individual customer needs:

- Stand alone control or multi-point control panels
- Custom configured software interface for local, remote, or centralized control and monitoring

THE BEST IN MONITORING

MasterTrace Heat Tracing Systems maximize the performance and reliability of all electrical heat tracing applications. Sensing all critical heat trace variables and using the advanced algorithms of its microprocessor, MasterTrace can then warn you of potential problems before they become critical, maintaining your heat trace system 24-hours a day, 365 days of the year.

MasterTrace continuously monitors your heat tracing and provides you with user-settable alarms for temperature, heater current and ground fault current, all independent of the trip levels. Your heat tracing system is critical to your plant operations so MasterTrace Systems are designed to perform self-check monitoring on all RTD's and switches. To further ensure that your heat trace works when you need it, Nextron's TraceCheck™ feature periodically energizes and checks for alarm conditions on all dormant lines and latches onto alarm functions.

ADVANCED CONTROL

The advanced features of MasterTrace allow it to handle single-phase to three-phase heat trace applications with switch ratings up to 100A @ 600VAC. Integral user-settable ground fault trip protects your heat trace without costly ground fault breakers. The user-settable Ground Fault test function lets you know if Ground Fault monitoring is functioning properly.

RTD inputs (dual RTD inputs available) have a user-settable fail-safe strategy. A Master Override input allows for external control for load-shedding or ambient control.

FRIENDLY INTERFACING

MasterTrace interfaces make interrogation and programming easy in all MasterTrace controllers.

- Two choices are available:
- Local Interface (ML100)
 - Remote Interface (MR100)

ML100 communicates with a single controller of up to 10 circuits and up to 5 feet away.

MR100 communicates with multiple controllers, up to 30 controllers or 300 circuits, to a maximum of 4000 feet without repeaters.



ENERGY MANAGEMENT

Operators have many reasons to reduce their environmental impact, yet may be missing substantial opportunities to become greener without making significant investments. Opportunities for energy savings are in perhaps the most obvious of places — the plant.

Monitoring energy and energy costs are the starting points and MasterTrace provides you with the tools through the measured values of: Heater Utilization, Power Consumption (MWh), and Operating Costs (\$0 to \$1,000,000)

A SYSTEM WITH A FUTURE

MasterTrace is the most complete system of heat tracing controllers. MasterTrace can handle all your heat trace control requirements and is the only heat trace system that offers Local, Group and Central Computer Interfaces (See MC100).

MasterTrace combines the power and flexibility you need today with the ability to expand to meet your needs for the future.

MC100 SOFTWARE PACKAGE



For plant wide monitoring the MC100 for windows software package provides programming and monitoring for MasterTrace heat tracing controllers on a PC. Process setpoints and alarm levels are programmed for each heater through the computer keyboard, reducing data entry on large systems. Setpoint programming and configuration functions are password protected to restrict access. By connecting individual MasterTrace modules or panels together, heat tracing throughout an entire plant can be programmed and monitored from a single location.

A Quality Company



ISO 9001

QMI SAI GLOBAL REGISTERED

Catalog Number	i)	# of circuits					
Switch Type							
1-pole, external solid state			SXH				
2-pole, external solid state			DXH				
2-pole internal mechanical			DIH				
2-pole external mechanical			DXN				
Switch Rating							
No Switches	ii)	0					
30A, 280VAC Switches	iii)	2					
50A, 280VAC Switches	iv)	3					
100A, 280VAC Switches	iv)	4					
30A, 600VAC Switches	ii)	5					
50A, 600VAC Switches	ii)	6					
100A, 600VAC Switches	ii)	7					
Controller Options							
2nd RTD (DUAL RTD)				R			
Enclosure Options							
NEMA 4 EPOXY PAINTED STEEL					E1		
NEMA 4X FRP					E2		
NEMA 4X STAINLESS STEEL					E3		
Display Interface Options							
ML100 Local Display/Interface, no shroud						D1	
ML100 Local Display/Interface, with shroud						D2	
MR100 Group Display/Interface, no shroud						D3	
MR100 Group Display/Interface, with shroud						D4	
Control Power Voltage							
120VAC						Blank	
208VAC						X1	
240VAC						X2	
277VAC						X3	
480VAC						X4	
600VAC						X5	
Air Purging Options							
Non-Classified to Class 1, Div 1 (Mechanical Switch)							XP
Class 1, Division 2 to Division 2							YP
Non-Classified to Class 1, Div 2 (Mechanical Switch)							ZP
*Switch rating subject to derate against operating ambient temperature; Contact Factory for derating information							
Notes: i) SHADED FIELDS ARE MANDATORY ii) All EXCEPT DXH MODELS iii) All EXCEPT DIN MODELS iv) Models SXH and DXH ONLY							

MASTERTRACE SPECIFICATIONS

APPROVALS

Mechanical:

Solid-State:

Alarm Output:

Alarm Output Rating:

Control Power:

Switch Rating:

Temperature Input:

Heater Current Input:

Ground Fault Input:

Operating Range:

Communication Ports:

SERIAL COMMUNICATIONS

Type:

Protocol:

Transmission Rate:

Interconnect:

Highway Distance:

Modules per Highway:

CSA Ordinary (General Purpose) Areas
CSA Class 1, Division 2, Group A,B,C,D
CSA Class 1, Zone II Group IIC

Mechanical: 1.0A @ 120VAC max (ordinary areas)
10mA @ 30VAC max (Hazardous Areas)
Solid-state: 0.1A @ 30VAC max
120VAC

Internal: 30A @ 280VAC max.
External: 100A @ 600VAC max.
One or two 100Ω, Platinum, 3-wire
RTD per point, 20Ω max. lead resistance
+/- 0.2A accuracy over -50°C to +500°C

One current transformer per point
3% +/- 0.2A accuracy over 1.0A to 100A

One current transformer per point
5% +/- 2mA accuracy over 0.01 to 3.0A

-40°C to +60°C (LCD screen -20°C to +60°C)

(1) Parallel Local Interface connection
(2) Serial Network connections

RS 485

Modbus® RTU

1200-9600 baud

2-wire, shielded, twisted pair

4,000 feet without a repeater

(1) Interface and (30) Control Modules

MEASURED VALUES

Temperature: -50°C to 500°C (-58°F to 932°F)
Minimum Temperature: -50°C to 500°C (-58°F to 932°F)
Maximum Temperature: -50°C to 500°C (-58°F to 932°F)
Heater Current: 1.0A to 100A
Heater Percent Power: 0 to 100%
Peak Heater Current: 1.0A to 100A
Ground Fault Current: 0.01A to 1.0A
Heater Utilization: 0 to 100%
Power Consumption: 0 to 1,000 MWh
Operating Cost: \$0.00 to \$1,000,000

ALARM MESSAGES

Temperature: High Temperature Alarm
Low Temperature Alarm
Current: High Current Alarm
Low Current Alarm
High Current Trip
Low Current Alarm
Ground Fault Current: Ground Fault Current Alarm
Ground Fault Current Trip
TraceCheck™: Switch Shorted
High Current Alarm
Low Current Alarm
High Current Trip
Ground Fault Current Alarm
Ground Fault Current Trip
Self-Check Failure, Switch Shorted
RTD Open, RTD Shorted

USER SETTABLE OPTIONS

Heater Status: Enable or Disable
Heater Name or Tag: 16 Character Alphanumeric
Temperature Units: °C or °F
Control Strategy: ON-Off or Proportional(=)
Deadband: 0° to 50°C (0°F to 90°F)
Stagger Start(=): ON or OFF
Power Limit(=): 1.0A to 100A
Temperature Setpoint: 0°C to 500°C (32°F to 932°F)
High Temperature Alarm: 0°C to 500°C (32°F to 932°F)
Low Temperature Alarm: -50°C to 500°C (32°F to 932°F)
High Current Alarm: 1.0A to 100A
Low Current Alarm: 1.0A to 100A
High Current Trip: 1.0A to 100A
Ground Fault Alarm: 0.01A to 1.0A
Ground Fault Trip: 0.01A to 1.0A
TraceCheck™ Interval: 1 to 24 hours
RTD Fail-Safe: Heater ON or Heater OFF
Master Override: ON or OFF
Alarm Contacts: NO or NC for each contact
Alarm Light: Alarm ON, Alarm OFF, Flash during alarm the ON, Flash during alarm then OFF

(=) Available on Solid-State Modules Only